

PAPER • OPEN ACCESS

Modernization of the buffer beam of PE2U traction unit electric locomotive

To cite this article: D Bannikov *et al* 2020 *IOP Conf. Ser.: Mater. Sci. Eng.* **985** 012035

View the [article online](#) for updates and enhancements.

Modernization of the buffer beam of PE2U traction unit electric locomotive

D Bannikov^{1,2}, A Radkevich¹ and A Muntian¹

¹Dnipro National University of Railway Transport named after Academician V. Lazaryan, Lazaryan str., 2, 49010, Dnipro, Ukraine

²bdo2020@yahoo.com

Abstract. The article presents the main results of a theoretical study on the analysis of the stress-strain state of the construction of the buffer bar of the electric locomotive for the control of the traction unit PE2U. The estimation of the possibility and effectiveness of attachment on the front wall of the buffer beam of a special securing bracket was considered as a separate task. In both cases, the finite element method based on the SCAD for Windows computing system was used. As a result, it was found that in general, the design of the buffer beam does not meet the requirements of the current standards. Up to 5 zones of high stress concentration are present in the structure, which, given the long service life of the machines (up to 40-50 years), are potential places for the development of fatigue damage. In order to balance the stress level, we recommended to strengthen the contact zone of the supports under the automatic coupling with the system of horizontal truss plates. The additional recommendation is to reinforce the lower sheet of the buffer beam structure up to and including its replacement by a sheet of greater thickness. Attachment to the front wall of the buffer beam of a special securing bracket for holding in emergency mode the coupling of the locomotive-car is possible provided that this zone is strengthened by the system of additional truss plates. The total increase in the mass of the buffer beam reaches 350 kg (25 % of the original weight of the buffer beam structure).

1. Introduction

Nowadays, a number of mining enterprises in Ukraine and the CIS countries continue to operate the PE2 series traction units. They have been developed and put into operation since the 1960s at the Dnepropetrovsk Electric Locomotive Building Plant (currently – SE Dniprovskiy Electric Locomotive Building Plant, Ukraine). Further, the traction unit was upgraded with a partial improvement of traction characteristics and was designated PE2U (Figure 1). It consisted of a DC (direct current) electric locomotive and two self-propelled dumping cars. In practice, the electric locomotive is often used as an independent traction unit of rolling stock, such as a locomotive.

As the life span of many of these machines is 40-50 years, more and more often their operation is accompanied by various failures and accidents due to the high level of abrasion of the structural elements. One such important structural element is the buffer beam, which directly receives the force of the automatic coupling. Therefore, special attention is paid to monitoring of its reliable operation.

Due to the widespread use of structural analysis software, mainly on the basis of the finite element method [1, 2], it has become possible to estimate the stress-strain state (SSS), including the buffer beam. Its calculations and design were done in its time using rather simplified models, and of course the spatial work of this construct was not taken into account.





Figure 1. Traction unit PE2U.

Although the analysis of the SSS of various units of rolling stock is already quite commonplace both in domestic [3, 4] and in foreign practice [5, 6], however, there is no study of the construct of the PE2 series traction unit. The [7] presents the results of solution to the problem of balancing of this machine, yet the problem has been solved analytically without the use of the finite element method.

2. The purpose and objectives of the study

The main purpose of the conducted research was to estimate the SSS of the buffer beam of the electric locomotive of the PE2U traction unit with the provision of appropriate recommendations for improvement of its operation.

An additional practical task that was also considered during the research was to evaluate the possibility and effectiveness of attaching a special securing bracket to the front wall of the buffer beam. The function of this bracket is to keep the locomotive-car coupled in case of uncoupling when riding on steep inclines or in connection with abrasion and damage to the automatic coupling. The retention implied the presence of an additional chain, which was attached to the securing bracket. In fact, it is an additional emergency safety measure that has begun to be put into practice when operating electric locomotives, which is the variant of modernization of the buffer beam structure.

3. Research methodology

Structurally, the buffer beam is a complex spatial lamellar structure with overall dimensions of 2.1×1.5 m. On the sides, the beam joins the supporting side members of the locomotive underframe, which have a box section. The height of the buffer beam is 0.4 m. The top sheet has a thickness of 1 cm, the bottom sheet – 1.4 cm. In the structure of the buffer beam there are four vertical walls with a thickness of 0.8 cm, which connect the top and bottom sheets. The lower sheet and the vertical walls are provided with openings which somewhat lighten the structure. The central part of the buffer beam, which houses the automatic coupling system, has an additional system of special supports and fasteners. The total weight of the buffer beam structure reaches 1 400 kg.

The assessment of the SSS of the buffer beam structure was performed using the design-computing complex SCAD for Windows [8]. Although it is building-oriented software, it can be fairly correctly applied to the analysis of the work of machine-building structures, which is presented in [9].

A separate issue of the buffer beam structure modelling was that of taking into account a certain length of the supporting side members of the locomotive underframe, as it affects significantly the distribution of efforts in the structure. It was experimentally determined that modeling of beams at a length of 1.5 m from the back wall of the buffer beam (approximately 4 beam heights) is acceptable. This is sufficient to avoid the effect of the beam stiffness on the buffer beam structure SSS. The

fastening of the model was made around the perimeter of the beam, as shown on Figures 2-4 in red lines. It was as rigid fastening according to results of researches presented in work [9].

The finite element model of the buffer beam structure was a plate system. The main defining type of loads, in accordance with the current norms [10, 11], was taken longitudinal compression force of 250 tons. When analysing the work of the securing bracket there was given a tensile load of 70 tons. These loads are shown on the Figure 2 and Figure 4.

Since the load was assumed to be symmetrical, half of the structure of the buffer beam was modeled geometrically with the task of the necessary conditions of symmetry of deformations (shown on Figures 2-4 in blue lines). As finite elements, we assumed a universal isoparametric shell finite element, available in the finite element base of used software complexes SCAD for Windows. Its use made it possible to reduce the total number of finite elements in the calculation model without losing the required accuracy of the obtained results [12]. Therefore, the overall dimension of the calculation model turned out to be relatively small – nodes within the order of 60,000, elements within the order of 65,000 with a total number of degrees of freedom within the order of 300.000.

4. Research results and their discussion

4.1. Stress-strain state of the buffer beam structure

Having assessed the stress-strain state (SSS) of the electric locomotive buffer beam structure of the PE2U traction unit, we should state the following. The most loaded element of the buffer beam is the internal vertical wall, which has supports that receive the load from the coupling. The stress level in it reached 330 MPa (zone G in Figure 2). You can also distinguish 3 more zones in the structure of the buffer beam, in which the stress level reaches 170-190 MPa. They are all located on the lower sheet. In other parts of the structure, the stress-strain state is more uniform and the stresses do not exceed the level of 100 MPa in total (Table 1). Due to the out-of-center application of the load from the coupling, we observed a vertical deformation of the buffer beam structure, which reached 18 mm.

It is worth noting that the allowable stress level for the buffer beam structure made from steel 295-09Г2С according to norm [10, table 5.1] is 265 MPa (for mode 1) and 195 MPa (for mode 2). Therefore, given the long life of PE2U machines, it is recommended to carry out special fatigue tests on samples taken from specified stress concentration points especially for zone G, where the level of stresses is higher than allowable stress level.

Such SSS required some measures to strengthen the structure of the buffer beam. For this purpose, we analyzed 6 structural variants of reinforcement of the support zone with the truss plates system. In this case, both their vertical and horizontal positions were considered. The most effective option was the setting of four horizontal truss plates, 16 mm thick each, which reduced the level of tension in this zone almost twice (Figure 3, Table 1). Additional local structural changes were also proposed to balance SSS of the buffer beam structure. The stress state of it is shown on Figure 4 and Figure 5 for variants № 1 and № 4 according to the Table 1.

4.2. Stress-strain state of the buffer beam structure with a securing bracket

Attaching of a special securing bracket, as shown by the simulation results, significantly worsens the SSS of the front wall of the buffer beam. The stress level in individual areas increases to 370 MPa (Figure 6, Table 2).

For SSS balancing, we analysed the system of special reinforcing truss in vertical, horizontal, fan-shaped and combined positions. As a result, the most rational variant was determined, which, however, led to increased weight of the buffer beam structure (together with the securing bracket) by almost 350 kg. Also, according to the results of the assessment of the SSS of the securing bracket itself, a number of recommendations were given to improve and modernize its structural concept.

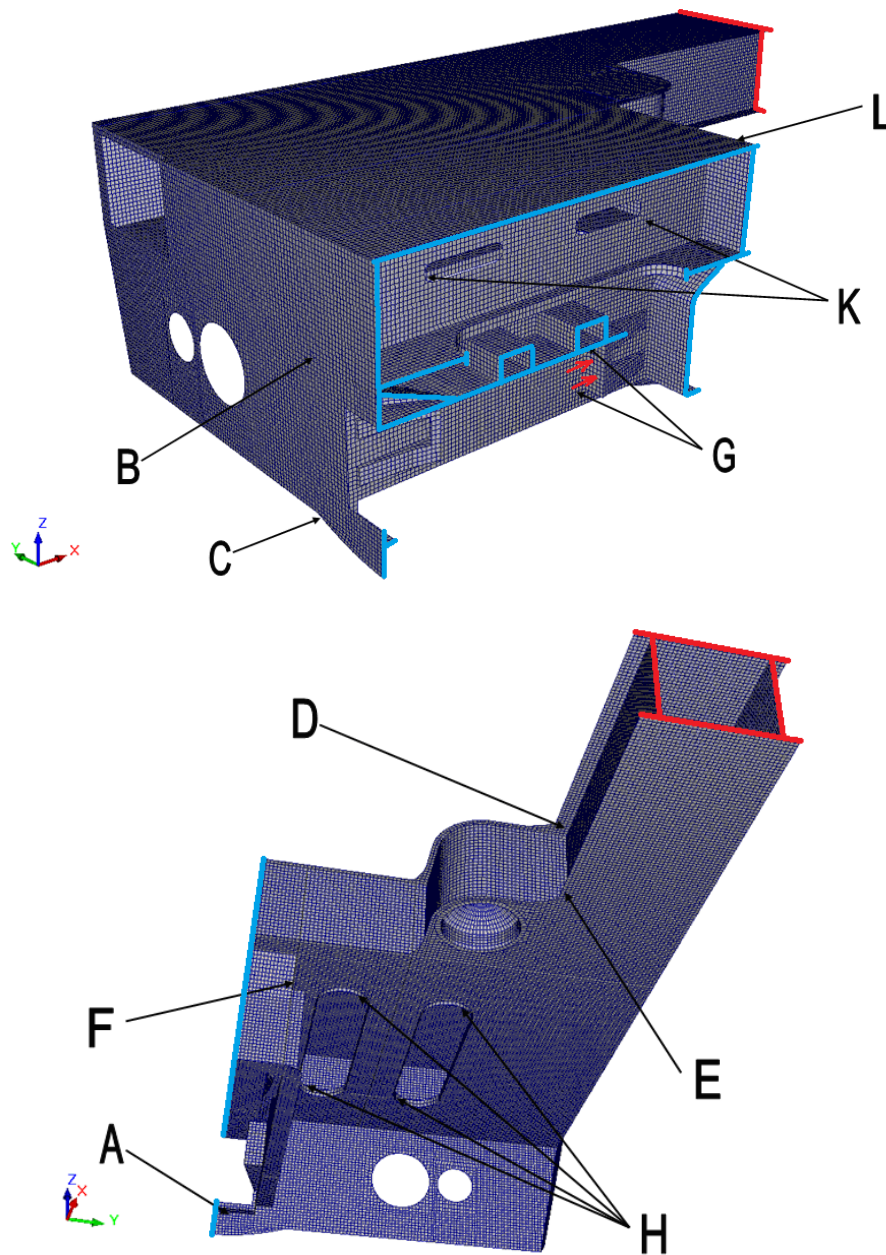

Figure 2. Stress concentration zones in buffer beam structure of PE2U traction unit.

Table 1. Level of stresses in the buffer beam structure of the PE2U traction unit (MPa).

Stress concentration zone									
A	B	C	D	E	F	G	H	K	L
1.Initial structure variant									
51	78	97	86	184	172	327	170	53	85
2.Vertical truss plate structure variant									
49	77	97	86	184	169	297	169	51	85
3. Horizontal truss plate structure variant (shortened)									
46	78	98	86	184	168	248	170	50	85
4. Horizontal truss plate structure variant (full length)									
45	78	98	86	184	162	170	170	51	85

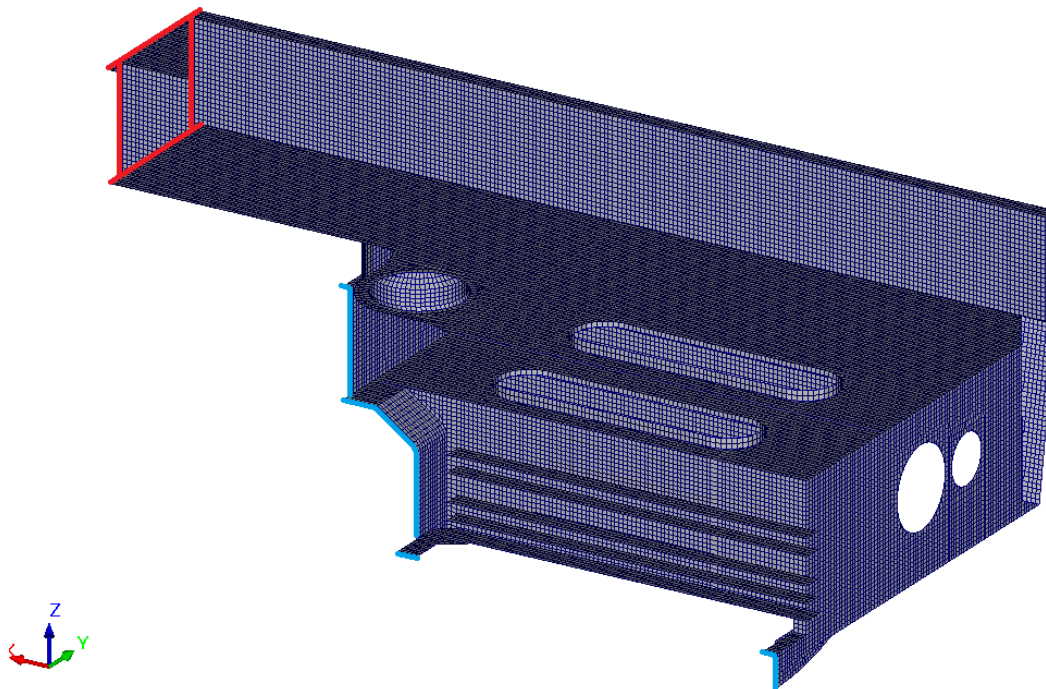

Figure 3. Strengthening of support zone with truss plates system in the buffer beam structure of PE2U traction unit.

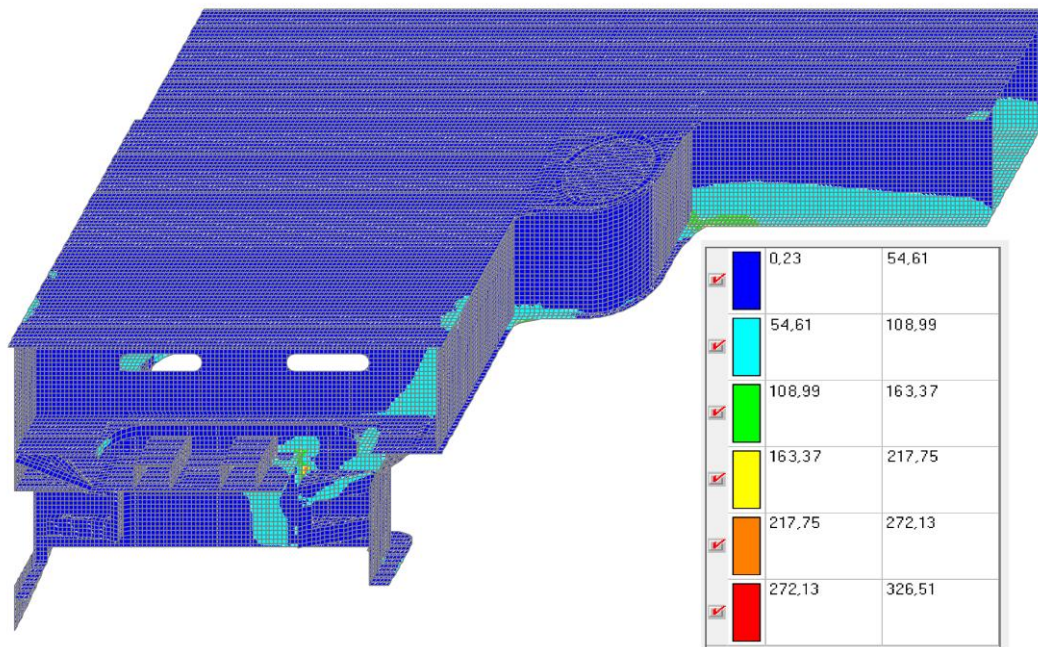

Figure 4. Stress state (MPa) of initial structure variant for the buffer beam structure of PE2U traction unit.

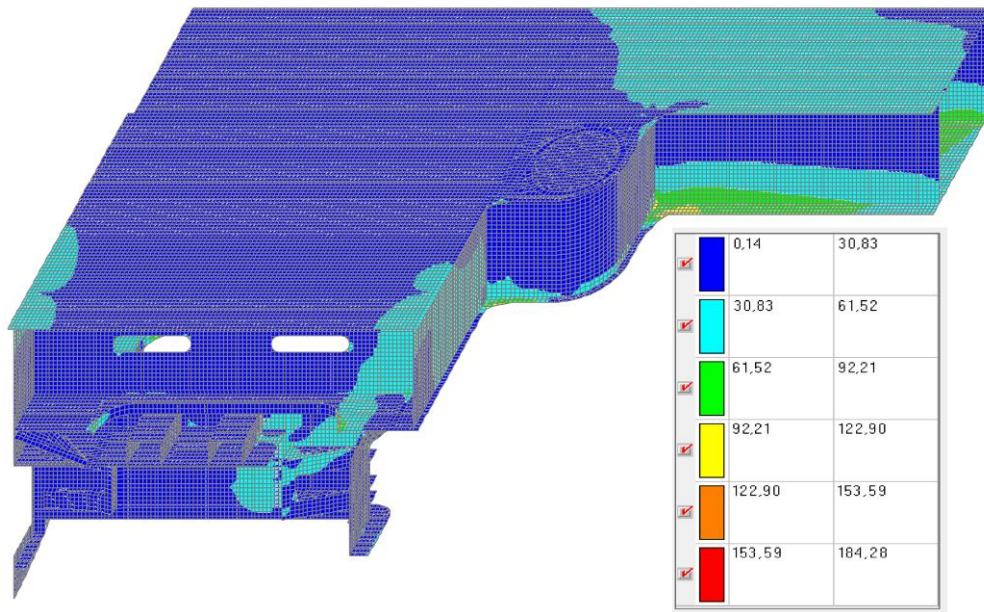

Figure 5. Stress state (MPa) of horizontal truss plate structure variant (full length) for the buffer beam structure of PE2U traction unit.

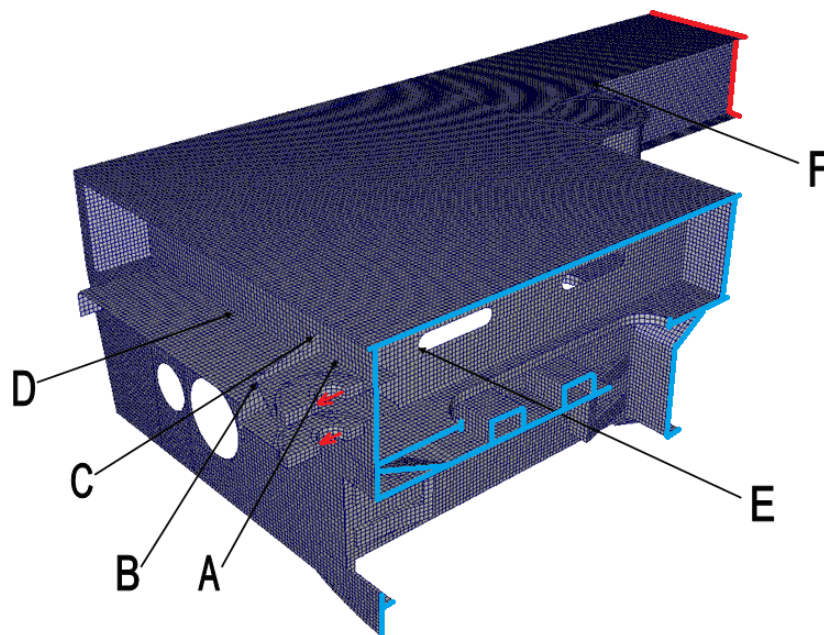

Figure 6. Stress concentration zones in buffer beam structure of PE2U traction unit with securing bracket.

Table 2. Level of stresses in the buffer beam structure of the PE2U traction unit with the securing bracket (MPa).

Stress concentration zone					
A	B	C	D	E	F
1. Initial variant of the structure with bracket					
368	330	230	184	121	112
2. Final variant of the structure with bracket					
160	177	123	102	85	74

5. Conclusions

The performed studies of the assessment of the stress-strain state of the locomotive buffer beam structure of the PE2U traction unit allowed us to make the following conclusions:

- In general, the design of the buffer beam does not meet the requirements of the current standards. Up to 5 zones of high stress concentration are present in the structure, which, given the long service life of the machines (up to 40-50 years), are potential places for the development of fatigue damage.
- In order to balance the stress level, we recommended to strengthen the contact zone of the supports under the automatic coupling with the system of horizontal truss plates. The additional recommendation is to reinforce the lower sheet of the buffer beam structure up to and including its replacement by a sheet of greater thickness.
- Attachment to the front wall of the buffer beam of a special securing bracket for holding in emergency mode the coupling of the locomotive-car is possible provided that this zone is strengthened by the system of additional truss plates. The total increase in the mass of the buffer beam reaches 350 kg (25 % of the original weight of the buffer beam structure).

References

- [1] Kovtunenkov V A and Kunisch K 2018 Revisiting generalized FEM: a Petrov–Galerkin enrichment based FEM interpolation for Helmholtz problem *Springer Science and Business Media LLC in Calcolo* **55** 38
- [2] Perig A and Matveyev I 2019 FEM-based deformation regression analysis of ECAE strains *FME Transactions* **47** 4 pp 851–855
- [3] Myamlin S, Lunys O, Neduzha L and Kyryl'chuk O 2017 Mathematical Modeling of Dynamic Loading of Cassette Bearings for Freight Cars *Proc. of 21st Int. Sci. Conf. Transport Means 2017* pt. III (Juodkrante, Lithuania: Kaunas Univ. of Technology) pp 973–976
- [4] Kostritsa S, Pshinko A, Ursulyak L, Kuzyshyn A, Kramarenko M and Grechkin A 2019 Stress-strain state analysis of the leading car body of DPKr-2 diesel train under action of design and operational loads *MATEC Web of Conferences* **294** 03018
- [5] Slavchev S, Stoilov V and Purgic S 2015 Static strength analysis of the body of a wagon *Journal of the Balkan Tribological Association* **21** 1 pp 38–57
- [6] Shukri A, Willem D and Anas Y 2016 Modeling aspects of the design of railway vehicle structures and their crashworthiness *Proceedings of the Institution of Mechanical Engineers, Part F: Journal of Rail and Rapid Transit* **230** 6 pp 1575–1589
- [7] Bannikov D and Radkevich A 2019 Analytical method for compiling and applying a ballast map for the traction unit PE2U *Eastern-European Journal of Enterprise Technologies: Engineering technological systems* **2-1** 98 pp 6–14
- [8] Karpilovskij V S, Kriksunov Je Z, Maljarenko A A, Fialko S Ju, Perel'muter A V and Perel'muter M A 2015 SCAD Office. Version 21. Computing complex SCAD++ Moscow: SCAD SOFT p 848
- [9] Bannikov D 2018 Usage of construction-oriented software SCAD for analysis of work of machine-building structures *Science and Transport Progress. Bulletin of Dnipropetrovsk National University of Railway Transport* **1** 73 pp 98–111
- [10] Norms for calculating and evaluating the strength of load-bearing elements, dynamic qualities and impacts on the track of the crew of locomotives of railways of the Ministry of Railways of the Russian Federation of 1520 mm gauge 1998 Moscow: VNIIZHT p 145
- [11] TU U 35.2-32495626-010-20 Traction units. Technical specifications 2003 Dnepropetrovsk: DEVZ p 48
- [12] Nastran J, Sircelj B, Gams M and Bokal D 2019 Sensitivity analysis of computational models for solving paradox *Journal of Networking technology* **1** 10 pp 18–24