

*MONOGRAPH*

***SCIENTIFIC RESEARCH  
IN MODERN CONDITIONS  
OF INSTABILITY '2023***



*BOOK 24  
PART 1*

---

*SWorld*  
Germany



*Proidak Y., Obodovych O.M., Zelenko Y., Dudarev I.M., Kuzmin O.V. et al.*

---

**WISSENSCHAFTLICHE FORSCHUNG UNTER  
MODERNEN BEDINGUNGEN DER INSTABILITÄT  
INNOVATIVE TECHNOLOGIE, VERKEHRSENTWICKLUNG, ARCHITEKTUR UND  
BAUWESEN**

*SCIENTIFIC RESEARCH IN MODERN CONDITIONS  
OF INSTABILITY*

INNOVATIVE TECHNOLOGY, TRANSPORT DEVELOPMENT,  
ARCHITECTURE AND CONSTRUCTION

---

*Monographic series «European Science»  
Book 24. Part 1.*

*In internationalen wissenschaftlich-geometrischen Datenbanken enthalten  
Included in International scientometric databases*

**MONOGRAPHIE**  
*MONOGRAPH*

*ScientificWorld-Net Akhat AV  
Karlsruhe 2023*

*Authors:*

Tryputen M. (1), Kuznetsov V. (1), Zhadanos O. (2), Proidak Y. (2), Derevyanko I. (2),  
Petrenko M. (2), Obodovych O.M. (3), Sydorenko V.V. (3), Tselen B.Y. (3),  
Stepanova O.E. (3), Rezakova T.A. (3), Semerak M.M. (4), Rymar T.I. (4),  
Sumakhina G.O. (5), Naumenko N.V. (5), Melnyk O.P. (6), Kuzmin O.V. (6),  
Niimirich O.V. (6), Mamchenko L.Y. (6), Dudarev I.M. (6), Lytovchenko O.M. (6),  
Kalinichenko T.V. (7), Cherkudinov V. (8), Zelenko Y. (8), Mysak I.V. (9, 10)

*Reviewers:*

*Chornyi Oleksii*, Doctor of Science, Director of the Educational and Scientific Institute of  
Electromechanics, Energy Saving and Control Systems (1)  
*Kremenchuk Mykhailo*, Ostrohradskyi National University (1)  
*Valerii Tytiuk*, Doctor of Science, Kryvyi Rih National University (1)  
*Kamkina Lyudmila*, Doctor of Technical Sciences, Professor, Ukrainian state university of  
science and technologies (2)  
*Manachyn Ivan*, Candidate of Technical Sciences (Ph.D), Associate Professor, Institute of iron  
metallurgy (2)  
*Gorobets Valeriy Hryhorovych*, Dr.Sci., Professor, National university of life and  
environmental sciences of Ukraine (3)  
*Frolova Natalia Epinetivna*, Professor, Doctor of Engineering Sciences, National University of  
Food Technologies (6)  
*Golovan Andrii*, PhD, Associate Professor, ONMU (7)  
*Yaroslav Bolzhelarskyi*, candidate of technical sciences, associate professor, Institute of  
Mechanical Engineering and Transport, Lviv Polytechnic National University (8)

**Wissenschaftliche Forschung unter modernen Bedingungen der Instabilität:** Innovative Technologie, Verkehrsentwicklung, Architektur und Bauwesen. Monografische Reihe «Europäische Wissenschaft». Buch 24. Teil 1. 2023.

**Scientific research in modern conditions of instability:** Innovative technology, Transport development, Architecture and construction. Monographic series «European Science». Book 24. Part 1. 2023.

**ISBN 978-3-98924-006-3**

**DOI: 10.30890/2709-2313.2023-24-01**

**Published by:**

*ScientificWorld-NetAkhatAV*

*Lußstr. 13*

*76227 Karlsruhe, Germany*

e-mail: [editor@promonograph.org](mailto:editor@promonograph.org)

site: <https://desymp.promonograph.org>

Copyright © Authors, 2023

Copyright © Drawing up & Design. ScientificWorld-NetAkhatAV, 2023



## ÜBER DIE AUTOREN / ABOUT THE AUTHORS

1. *Tryputen Mykola*, Candidate of Technical Sciences, associate professor, Dnipro University of Technology - *Chapter 1 (co-authored)*
2. *Kuznetsov Vitaliy*, Candidate of Technical Sciences, Associate Professor, Ukrainian State University of Science and Technologies - *Chapter 1 (co-authored)*
3. *Zhadanos Oleksandr*, Candidate of Technical Sciences, Associate Professor, Ukrainian state university of science and technologies - *Chapter 2 (co-authored)*
4. *Proidak Yurii*, Doctor of Technical Sciences, Professor, Ukrainian state university of science and technologies - *Chapter 2 (co-authored)*
5. *Derevyanko Ihor*, Candidate of Technical Sciences, Associate Professor, Ukrainian state university of science and technologies - *Chapter 2 (co-authored)*
6. *Petrenko Maksym*, graduate student, Ukrainian state university of science and technologies - *Chapter 2 (co-authored)*
7. *Obodovych Oleksandr Mykolaiovych*, Doctor of Technical Sciences, Professor, Institute of Engineering Thermophysics of National academy of sciences of Ukraine - *Chapter 3 (co-authored)*
8. *Sydorenko Vitalii Volodymyrovych*, Candidate of Technical Sciences, senior researcher, Institute of Engineering Thermophysics of National academy of sciences of Ukraine - *Chapter 3 (co-authored)*
9. *Tselen Bohdan Yaroslavovych*, Candidate of Technical Sciences, senior researcher, Institute of Engineering Thermophysics of National academy of sciences of Ukraine - *Chapter 3 (co-authored)*
10. *Stepanova Olesya Evgeniivna*, Candidate of Technical Sciences, senior researcher, Institute of Engineering Thermophysics of National academy of sciences of Ukraine - *Chapter 3 (co-authored)*
11. *Rezakova Tetyana Anatoliyivna*, Candidate of Technical Sciences, senior researcher, Institute of Engineering Thermophysics of National academy of sciences of Ukraine - *Chapter 3 (co-authored)*
12. *Semerak Mykhailo Mykhailovych*, Doctor of Technical Sciences, Professor, Lviv Polytechnic National University - *Chapter 4 (co-authored)*
13. *Rymar Tetiana Ivanivna*, Candidate of Technical Sciences, Associate Professor, Lviv Polytechnic National University - *Chapter 4 (co-authored)*
14. *Sumakhina Galyna Oleksandrivna*, Doctor of Technical Sciences, Professor, National University of Food Technologies - *Chapter 5 (co-authored)*
15. *Naumenko Nataliia Valentynivna*, Doctor of Philology, Professor, National University of Food Technologies - *Chapter 5 (co-authored)*
16. *Melnyk Oksana Petrivna*, Candidate of Chemical Sciences, Associate Professor, National University of Food Technologies - *Chapter 6 (co-authored)*



17. *Kuzmin Oleh Volodymyrovych*, Doctor of Technical Sciences, Professor, National University of Food Technologies - *Chapter 6 (co-authored)*
18. *Niemirich Oleksandra Volodymyrivna*, Doctor of Technical Sciences, Professor, National University of Food Technologies - *Chapter 6 (co-authored)*
19. *Mamchenko Liudmyla Yevhenivna*, Candidate of Technical Sciences, Associate Professor, National University of Food Technologies - *Chapter 6 (co-authored)*
20. *Dudarev Igor Mykolaiovych*, Doctor of Technical Sciences, Professor, Lutsk National Technical University - *Chapter 6 (co-authored)*
21. *Lytovchenko Oleksandr Mykhailovych*, Doctor of Technical Sciences, Professor, Institute of Horticulture NAAS of Ukraine - *Chapter 6 (co-authored)*
22. *Kalinichenko Tetiana Valentynivna*, graduate student, State University Infrastructure and Technologies - *Chapter 7*
23. *Cherkudinov Volodymyr*, graduate student, Ukrainian State University of Science and Technologies - *Chapter 8 (co-authored)*
24. *Zelenko Yuliya*, Doctor of Technical Sciences, Professor, Ukrainian State University of Science and Technologies - *Chapter 8 (co-authored)*
25. *Mysak Ihor Vasylovych*, Candidate of Technical Sciences, Lviv Polytechnic National University - *Chapter 9, Chapter 10*



## Inhalt / Content

### CHAPTER 1

#### ON THE FEASIBILITY OF CHOOSING MEANS OF AN ASYNCHRONOUS MOTOR PROTECTION IN INDUSTRIAL CONDITIONS

Introduction .....	8
1.1. Representation of static processes in discrete form .....	10
1.2. Process optimization based on the predicate model .....	14
1.3. Predicate model transformations.....	18
3.3.1. Predicate model transformations by sub-domains consolidation .....	18
3.3.2. Predicate model transformations by combining boundary sub-domains .....	21
3.3.3. Encoding of the predicate model elements .....	25
1.4. The choice of AM protection means on the basis of the predicate model "electrical network – asynchronous motor" .....	28
Conclusions .....	34

### CHAPTER 2

#### IMPLEMENTATION OF SUSTAINABLE DEVELOPMENT CONCEPTION AT THE UKRAINIAN METALLURGY ENTERPRISES

Introduction .....	35
2.1. A brief description of the Nikopol ferroalloy plant .....	37
2.2. General characteristics of dust and gas emissions during the production of manganese ferroalloys .....	39
2.3. Improvement of dust and gas emission cleaning systems .....	43
2.4. Audit of carbon dioxide emissions during agglomeration of manganese ore raw materials and smelting of manganese ferroalloys.....	45
2.5. Reduction of carbon dioxide emissions due to the use of ferroalloy gas as an energy source.....	47
2.6. Evaluation of the efficiency of the gas cleaning systems at JSC "NFP" during the production of manganese ferroalloys based on the developed mathematical model of dispersion of aspiration dust and gas emissions ...	49
2.6.1. Analysis of methods for modeling the distribution of dust and gas emissions from stationary sources taking into account the conditions of ferroalloy production .....	49
2.6.2. Modeling and analysis of results .....	55
Conclusions .....	57



# KAPITEL 1 / CHAPTER 1<sup>1</sup>

## ON THE FEASIBILITY OF CHOOSING MEANS OF AN ASYNCHRONOUS MOTOR PROTECTION IN INDUSTRIAL CONDITIONS

DOI: 10.30890/2709-2313.2023-24-01-026

### Introduction

In [1-6], the main ways to reduce the negative impact of low-quality electricity on the operation of an electric motor in industrial conditions, and, therefore, on production efficiency in general, were shown. They are as follows: the use of "individual" LC-filters to protect especially critical electric drives; the use of "group" devices for compensating the influence of low-quality supply voltage at the workshop level; suppression of supply voltage distortions in the places of their occurrence. Rejection to take any measures is also allowed, regardless of a significant reduction in motor life. Each of these options is characterized by a certain implementation cost and expected economic effect.

The method of choosing protection means for an asynchronous electric motor (AM), presented in [3, 4], is based on optimization computational experiments, during which the statistical patterns of changes in the main quality indicators of linear voltages in the electric network, electromagnetic and thermal modes of AM operation are reproduced. The practical implementation of these computational procedures involves the participation of specialists from various fields: economics, electrical engineering, modeling, programming. Obviously, there are no such specialists at industrial enterprises and it is required to attract special scientific and research structures.

At the same time, in industrial enterprises, the number of asynchronous motors can reach several tens and even hundreds of units. The involvement of scientific and research organizations in order to select the protection means for each motor separately will require huge costs and, therefore, it is not economically feasible. This contradiction can be resolved by making the choice of protection means available to the regular working personnel of an industrial enterprise.

Indeed, the decision on the economic feasibility of choosing a specific technical protection option (or rejecting it) depends on the values of technical  $\vec{X}$  and economical  $\vec{C}$  quantities. The technical quantities determine the current state of the electrical network and the asynchronous motor, and the economical ones determine the costs of

---

<sup>1</sup>Authors: Tryputen Mykola, Kuznetsov Vitaliy



the corresponding protective equipment. It is necessary to organize the process of AM operation in such a way that the economic damage to the enterprise from its operation in a non-sinusoidal electrical network is minimal.

The formulated task (intervention in the operation process of technical device) refers to control tasks. Technical and economical quantities are referred to as inputs. The goal of control is represented as follows:

$$E \rightarrow \min, \quad (1)$$

Here  $E$  is the economic damage from the use of technical AM protection means or their absence.

It is possible to determine the minimum economic damage  $E_{min}$  if we establish the dependence:

$$E = f(\vec{X}, \vec{C}) \quad (2)$$

An analysis presented above unambiguously indicates that dependence (4.2) is static, non-linear, non-stationary. Obviously, it is not possible to obtain it by analytical methods, and the implementation of experimental identification has certain difficulties due to the lack of a priori data on its structure. Therefore, it is impossible to apply one of the many known optimization methods to (1). In addition, the structure of dependence (2) is not constant due to the emergence of new protection means and taking into account additional quantities characterizing the quality of operation of the asynchronous motor and the state of the electrical network. But optimization methods are not focused on the adaptation of models.

Overcoming the difficulty in terms of improving the model (that is, refining its structure) is possible by using pattern recognition methods. Recognition methods are widely used for predicting the efficiency of technical devices, or assigning the expected mode of a technical device to one of predetermined classes – typical modes. But recognition methods are not adapted for solving optimization problems.

At the same time, methods of optimization and pattern recognition have much in common; their elements are present in each other. Optimization is the recognition of the best (optimal) solution from a set of possible ones; and recognition is the best (optimal) classification of an unknown object. It is obvious that overcoming the difficulties in solving the optimization problem based on a model with a variable structure is possible with the convergence of recognition and optimization methods.



### 1.1. Representation of static processes in discrete form

In [7], in order to solve the problems of identification and optimization of a nonlinear object, it was proposed to use a combined model of the form:

$$y = \left\{ \begin{array}{l} A_{01} + \vec{A}_{11} + \vec{X}, \text{ if } \vec{z} \in S_1 \\ \dots \dots \dots \\ A_{0k} + \vec{A}_{1k} + \vec{X}, \text{ if } \vec{z} \in S_k \end{array} \right\}, \quad (3)$$

Where  $\vec{X} = (x_1, \dots, x_m)$  is the vector of factors influencing the process;  $\vec{A}_{11}, \dots, \vec{A}_{1k}$  – vectors of intraclass linear regression coefficients;  $Z_1, \dots, Z_k$  – homogeneous classes in space  $(\vec{X}, y)$ .

The essence of the combined model is that the space of production situations is divided by pattern recognition methods into non-intersecting subsets (classes)  $Z_j$  ( $j = \overline{1, k}$ ), each of which corresponds to a certain operating mode of the equipment, and setting a specific operating mode in the form of a linear regression model suitable for solving the optimization problem. Thus, this model is a combination of the continuous part from the linear equations of multiple regression and the discrete part – the decision rules of the recognition system.

To solve the problem of automatic classification of production situations, a self-learning algorithm (taxonomy) is used. It allows us to automatically set the appropriate number of classes ( $m$ ) in the process of partitioning and synthesize decision rules (based on a given statistical dataset) in the form of two-valued predicates based on  $R$ -functions [Regarding the forecasting of production situations in the enrichment process [8]. The estimation of the parameters  $A_{0j}$  and  $A_{1j}$  the continuous part of the model is carried out based on elements of  $j$ -th class sample set using the least squares method.

The combined model can significantly improve the accuracy of the mathematical description of a non-linear object and facilitates the effective use of traditional linear optimization methods. And the adaptability of the  $R$ -functions method to adaptation provides the opportunity to continuously refine it in conditions of non-stationary processes and production situations. However, the cumbersomeness of this model is also obvious, which consists in the need to use five different types of algorithms: taxonomy, construction and analysis of predicate equations, construction of regression dependencies in each class, linear optimization.

This cumbersomeness is explained by the fact that the disadvantage of optimization methods (inadaptability to model refinement) and the lack of pattern recognition methods (inadaptability to optimization procedures) are eliminated by



simple arithmetic summation of these different but complementary groups of methods.

In the work [7] it is proposed to solve the problems of identification and optimal control tasks for an object only based on a recognition algorithm. Moreover, the proposed solution is focused on models presented as a logical sum of hyperparallelepipeds, each of which is described by a latch function.

Latch functions are simpler dependencies used to describe elementary areas and are focused on the application of recognition principles for solving practical problems that are characterized by non-linear separation, relatively high dimensionality, as well as the continuous, discrete and discrete-continuous nature of the feature space.

The essence of this approach is as follows. Let the feature space  $m$  of measurements be given,  $x_i$  are the coordinate axes of the space,  $i = \overline{1, m}$ . For clarity, we'll consider a two-dimensional space with axes  $x_1$   $x_2$  in fig. 1 (a, b).

It is assumed that the set of points in this space  $S$  corresponds to the set of certain objects. This set, in turn, includes subsets  $S_k$ , called patterns (classes):

$$Z \supseteq \bigcup_{k=1}^n Z_k \tag{4}$$

If the compactness hypothesis is true, we can assume that each image corresponds to its own area. The description of the areas, and, consequently, of the images, is made on the basis of the material of the preliminary training.

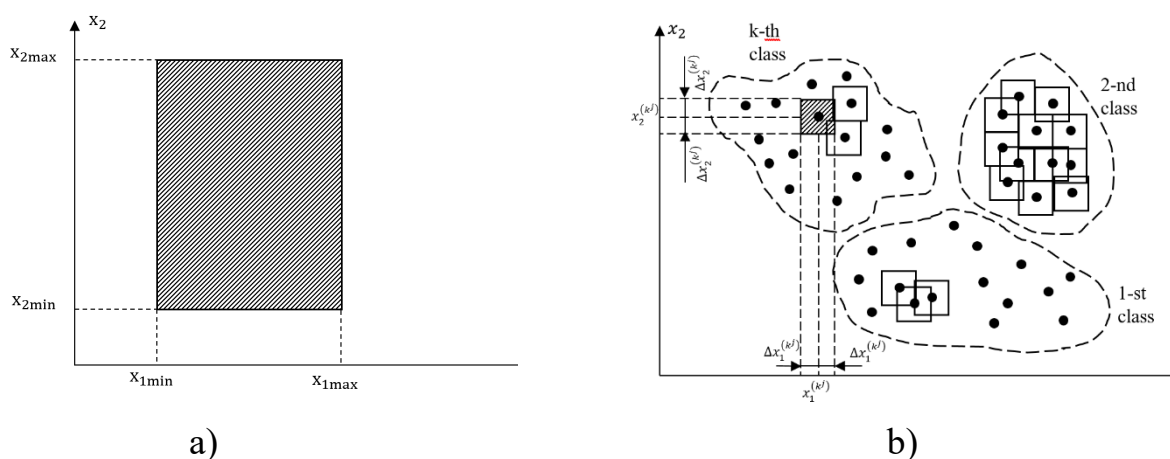

**Figure 1 – Graphical interpretation of the method of latch functions: a) two-dimensional parallelepiped; b) a set of parallelepipeds in the vicinity of training points**

Usually, during the training of a recognition system, an object is presented, meaning its coordinates are input into the feature space, and it is indicated to which pattern (class) it belongs. In this case, in addition to a specific value of a continuous coordinate, we can almost always indicate an interval in the vicinity of this value (for



example, due to the accuracy of measuring a physical or technological quantity) that does not go beyond the projection of the image area onto the corresponding coordinate axis. In other words, in the vicinity of the point corresponding to the training pattern, a subregion can be selected in the form of a  $m$ -dimensional rectangle.

To describe such an area, a function has been proposed, which is called the “latch function”. The name of the function reflects the appearance of intersecting rectangles that resemble latches (Fig. 1 b). This function has the following form:

$$P(x, x_{min}, x_{max}) = \begin{cases} a, & x_{imin} \leq x_i \leq x_{imax}, \forall i = \overline{1, m} \\ 0 & \text{in other cases} \end{cases}, \quad (5)$$

where  $x$  is the feature vector  $x = (x_1, x_2, \dots, x_m)$ ;  $x_{min}, x_{max}$  are vectors of function parameters;  $x_{min} = (x_{1min}, x_{2min}, \dots, x_{mmin})$ ;  $x_{max} = (x_{1max}, x_{2max}, \dots, x_{mmax})$ ;  $a$  is an arbitrary constant, and  $a > 0$ .

The latch function describes a subdomain of the feature space, which has the shape of  $m$ -dimensional parallelepiped. The number of its vertices is  $2^n$ . The coordinates of the vertices are all possible combinations  $x_{imax}$  and  $x_{imin}$  that have lengths equal to  $m$  (Fig. 1 a).

If some point of the attribute space is inside or on the border of the subdomain, then the function,  $P(x, x_{min}, x_{max})$  takes the value  $a$ , when the coordinates of the point are substituted into it. Otherwise, it is equal to zero.

On Fig. 1, b the training images are presented in the form of points in the feature space and the subregions in the vicinity of each of them are shown. Dotted closed lines depict the boundaries of the areas of the corresponding patterns (classes).

The subregion in the neighborhood of the  $j$ -th point of the  $k$ -th class is described by the latch function.

$$P(x, x_{min}^{(kj)}, x_{max}^{(kj)}) = \begin{cases} a, & x_{imin}^{(kj)} \leq x_i \leq x_{imax}^{(kj)}, \forall i = \overline{1, m} \\ 0 & \text{in other cases} \end{cases}, \quad (6)$$

where  $x_{min}^{(kj)}, x_{max}^{(kj)}$  are the vectors  $x_{min}^{(kj)} = (x_{1min}^{(kj)}, x_{2min}^{(kj)}, \dots, x_{mmin}^{(kj)})$ ,  $x_{max}^{(kj)} = (x_{1max}^{(kj)}, x_{2min}^{(kj)}, \dots, x_{mmax}^{(kj)})$ . Moreover  $x_{1min}^{(kj)} = x_i^{(kj)} - \Delta x_i^{(kj)}$ ,  $x_{1max}^{(kj)} = x_i^{(kj)} + \Delta x_i^{(kj)}$ . Here  $\Delta x_i^{(kj)}$  is the boundary of the admissible value of the  $i$ -th feature in the vicinity of the  $j$ -th point belonging to the  $k$ -th class.

In [9] Voronov V.A. has proved that for a sufficiently large number of uniformly distributed training points  $n_k$  and the corresponding parameters of the latch functions of these points, the separating function of the  $k$ -th class  $Z_k(x)$  can be represented by



the sum of the latch functions of the  $k$ -th class:

$$Z_k(x) = \sum_{j=1}^{n_k} P(x, x_{min}^{(kj)}, x_{max}^{(kj)}) \tag{7}$$

In addition, it was shown that if the  $l$ -th point falls into the  $k$ -th region “overlapped” by latch functions, then  $Z_k(x^{(l)}) = r \cdot a$ , where  $r$  is a positive integer. The meaning of the value  $r$  is the number of intersecting subdomains at the  $l$ -point. Obviously,  $r$  cannot be fractional and negative.

If we accept that  $a = 1$ , then the function (6) can take only two values 0 and 1 (false, true). A function with a set of values  $\{0, 1\}$  is called a predicate. Replacing the sign of the algebraic sum  $\Sigma$  with the sign of the logical sum (disjunction)  $\cup$  in formula (7), we obtain the logical sum of predicates, which also takes on the set of values  $\{0, 1\}$ :

$$Z_k(x) = \cup_{j=1}^{n_k} P(x, x_{min}^{(kj)}, x_{max}^{(kj)}) \tag{8}$$

The choice of the parameters of the latch function and the required number of training points is related to the accuracy of the areas approximation of the feature space by the set of subdomains described by the latch functions. It is not difficult to see that the smaller the value of the allowable boundary  $\Delta x_i^{(kj)}$  in the vicinity of each point and, accordingly, the greater the number of training points, the higher the accuracy of the approximation.

The implementation of the latch functions is based on the requirements of compactness and ease of implementation on a computer and on the basis of a selective mathematical expression [10]:

$$gn(b) = \begin{cases} 1 & \text{when } b \geq 0 \\ -1 & \text{when } b < 0 \end{cases} \tag{9}$$

Latch function for one-dimensional space ( $m = 1$ ) in Fig. 2 a, can be expressed in terms of function (9):

$$P(x, x_{min}, x_{max}) = \frac{1}{2} \{1 + sgn[(x - x_{min})(x_{max} - x)]\} \tag{10}$$

When  $m = 2$  (Fig. 2 b) expression (10) will take the following form:

$$\begin{aligned} P(x_1, x_2, x_{1min}, x_{2min}, x_{1max}, x_{2max}) &= \\ &= \frac{1}{2^2} \{1 + sgn[(x_1 - x_{1min})(x_{1max} - x_1)]\} \cdot \\ &\cdot \{1 + sgn[(x_2 - x_{2min})(x_{2max} - x_2)]\} \end{aligned} \tag{11}$$

The case of three-dimensional space ( $m = 3$ ) is shown in Fig. 2 c:

$$P(x_1, x_2, x_3, x_{1min}, x_{2min}, x_{3min}, x_{1max}, x_{2max}, x_{3max}) =$$



$$\begin{aligned}
 &= \frac{1}{2^3} \{1 + \operatorname{sgn}[(x_1 - x_{1\min})(x_{1\max} - x_1)]\} \cdot \\
 &\quad \cdot \{1 + \operatorname{sgn}[(x_2 - x_{2\min})(x_{2\max} - x_2)]\} \cdot \\
 &\quad \cdot \{1 + \operatorname{sgn}[(x_3 - x_{3\min})(x_{3\max} - \\
 x_3)]\} \quad (12)
 \end{aligned}$$

by induction on  $m$  the following final result is obtained:

$$P(x, x_{\min}, x_{\max}) = \frac{1}{2^m} \prod_{i=1}^m \{1 + \operatorname{sgn}[(x_i - x_{i\min})(x_{i\max} - x_i)]\} \quad (13)$$

Here  $x, x_{\min}, x_{\max}$  are vectors.

Expression (13) can also be used to describe a discrete space. Fig. 3 a shows a subdomain of a one-dimensional discrete space, including points  $x = 2, 3, 4, 5$  from the set  $0, 1, 2, 3, 4, 5 \dots$ . If we substitute the values  $x_{\max} = 5$  and  $x_{\min} = 2$  in expression (10), then we obtain a function that is equal to  $a$  at  $x = 2, 3, 4, 5$  and is equal to zero for all values of  $x$ .

In the case where the subdomain includes only one point, for example,  $x = 1$ , then it is described by the same latch function, but with  $x_{\min} = x_{\max} = 1$ .

By induction on  $m$  the validity of expression (13) is proven for discrete features.

The above is also true for a mixed space. If  $x_1, x_2$  are respectively discrete and continuous coordinates (Fig. 3 b), then after substituting them into (11) with pre-selected  $x_{1\min}, x_{2\min}, x_{1\max}, x_{2\max}$ , we obtain an expression that describes a subdomain that has a lattice form.

Thus, the latch function (13) allows us to describe subdomains in discrete, continuous, and mixed spaces.

## 1.2. Process optimization based on the predicate model

Description of production situations in  $m$ -space in the form of a logical sum of predicates allows us to include only those subdomains that correspond to a certain value of the control criterion in the class  $Z_k(x)$ . This can be done in the following way.

During the normal operation of a technological control object, a training dataset is formed, consisting of a vector of input quantities  $x$  and the corresponding output quantity, which determine the value of the control criterion  $y$ . In the process of forming classes based on elements of the sample population  $x$  – it is necessary, by setting different values of the optimization criterion  $y$  in the interval  $y_{\min} \div y_{\max}$ , to divide

the factor space into two patterns (classes):  $Z_1$ , if  $y_j \leq y$  and  $Z_2$ , if  $y_j > y$  ( $i = \overline{1, r}$ ). Here  $r$  is the volume of the sample population. If the value of the optimization criterion is changed with an interval  $\Delta y$ , then we'll obtain  $n = \frac{y_{max} - y_{min}}{\Delta y}$  classes, each of which is described by the predicate equation (8), (13).

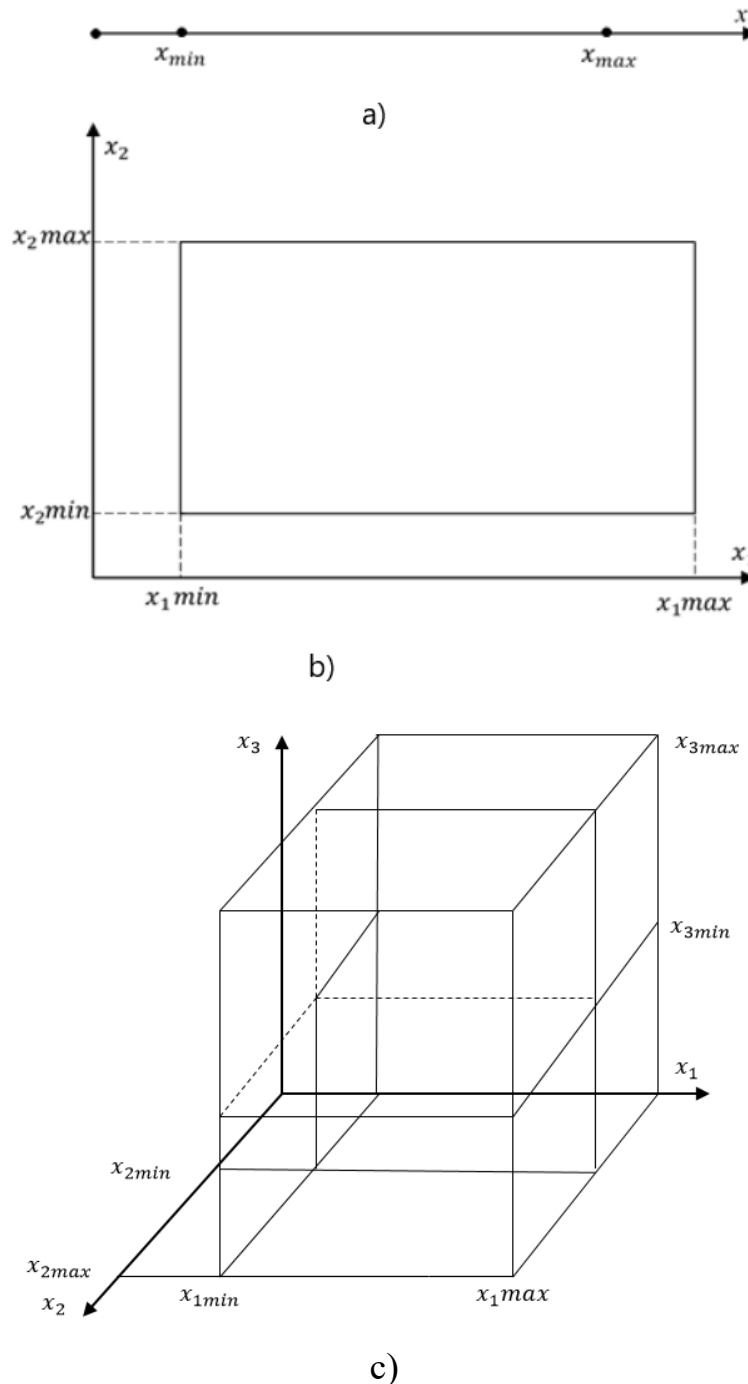

**Figure 2 – Types of parallelepipeds: a – one-dimensional; b – two-dimensional; c – three-dimensional**

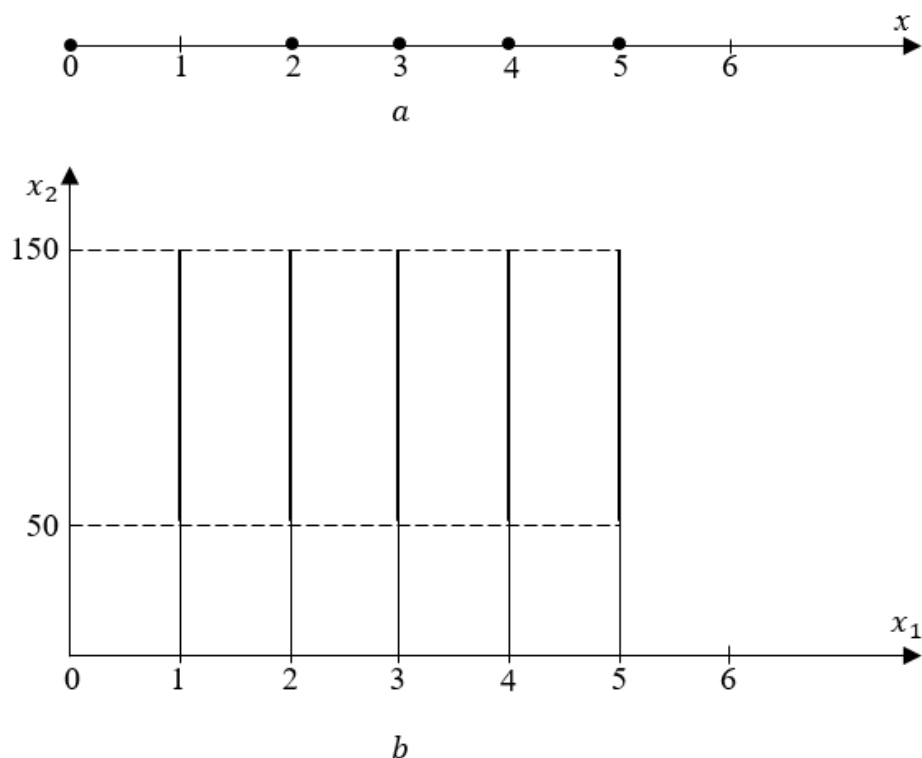

**Figure 3 – Types of space: a – one-dimensional discrete; b – two-dimensional mixed**

The model constructed in this way also implicitly contains the restrictions imposed on the conduct of the process, which made it possible to implement a simple optimal control algorithm without additional involvement of traditional optimization methods. The essence of this algorithm is as follows.

Of the factors influencing the process, control factors are distinguished  $x_1 \div x_v$  and the full range of their changes is presented as a series of values with an interval of  $\Delta x$ . Thus, all possible controls can be specified as combinations of these values. Then, by the values of the perturbing factors  $x_{v+1} \div x_m$ , it is sufficient to determine the truth of the predicate  $Z_1$  sequentially for all possible combinations of controls. The optimal control is the one that ensures the truth of the predicate. If, after enumeration of all controls by the predicate  $Z_1$  the optimal combination is not found, then it is necessary to expand the examined zone of the factor space by passing to the predicate  $Z_2$ , and so on.

Fig. 4 shows a graphical interpretation of the definition of optimal control. The vector of disturbing factors is conditionally plotted along the ordinate axis, and the vector of control variables is plotted along the abscissa axis. The model of the technological process consists of classes  $Z_k$  separating the surfaces (boundaries) of

which are shown in the figure by closed broken lines. Moreover, the area marked  $Z_1$  corresponds to the minimum value of the control criterion, and the area  $Z_n$  – to the maximum value. The vector of current values of disturbing factors is denoted by  $\vec{X}_{i2}^{cur}$ .

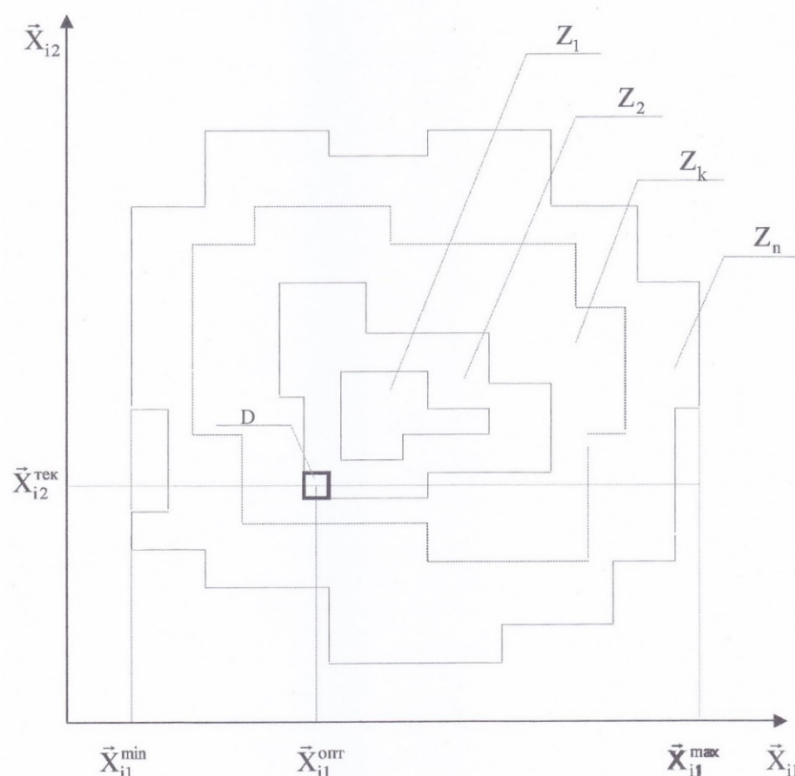

**Figure 4 – Search for optimal control**

As can be seen from Fig. 4 for a vector  $\vec{X}_{i2}^{cur}$  – the predicate defining the area (class)  $Z_1$  will be false for all possible combinations of control variables. For an area  $Z_2$  the corresponding predicate will give the true value for the combination of control actions  $\vec{X}_{i2}^{opt}$ . Vectors  $\vec{X}_{i2}^{cur}$   $\vec{X}_{i1}^{opt}$  form an elementary rectangle (generally, an elementary hyperparallelepiped in  $m$ -dimensional space)  $D1$ .

When optimizing a non-stationary static process, the predicate model (8) requires continuous refinement. It must be performed in two cases.

The first case occurs when a situation arises during the operation of a technological object that corresponds to the value of the criterion  $y_k$ , but it is absent in the class  $Z_k$  description. In [7] this uncertainty is called a contradiction of the first kind. The resolution of this contradiction is carried out by extending the class  $Z_k$  by adding the corresponding predicate to the model (8).

The second case occurs when a situation arises during the operation of a technological object that was previously included in the class  $Z_k$ , but now does not correspond to the value of the criterion  $y_k$ . This uncertainty is called a contradiction of



the second kind. It is impossible to exclude the predicate describing this situation from (4.8), since it defines an infinite set of situations that fall into the elementary hyperparallelepiped specified by it. The resolution of this contradiction is carried out by creating a subset of situations “attached” to the class  $Z_k$  that do not correspond to the value of the criterion  $y_k$ .

Then, according to [7], the refined predicate model  $Z_k$  will take the form (14):

$$Z_k(x) = \left[ \bigcup_{j=1}^{L_1+n_k} P \left( x, x_{min}^{(kj)}, x_{max}^{(kj)} \right) \right] \wedge \left[ \bigcup_{r=1}^{L_2} P \left( x, x_{min}^{(kr)}, x_{max}^{(kr)} \right) \right], \quad (14)$$

where  $L_1$  and  $L_2$  are the number of results of recognition of contradictions of the first and second kind, respectively;  $\wedge$  – logical multiplication sign (conjunction).

Thus, the considered optimization method allows solving problems of optimal static control of nonlinear objects without using the traditional mathematical formulation of such problems in the form of an objective function and restrictions. Predicate models in an integrated form represent the entire mathematical formulation of the problem. The undoubted advantage of this direction in solving optimization problems is the possibility of a relatively simple adaptation algorithm and the transition to describing an object in a factor space of a higher dimension.

At the same time, continuous refinement of the model will inevitably lead to an increase in the number of subsets “attached” to the class  $Z_k$  and, as a result, the complication of its structure with subsequent adjustments to the algorithm for choosing optimal control actions. This circumstance significantly complicates the optimization of non-linear non-stationary static objects.

### 1.3. Predicate model transformations

#### 1.3.1 Predicate model transformations by sub-domains consolidation

The problem of preserving the structure of predicate model (14) can be solved based on methods of patterns description reduction proposed in [2, 11]. The need to shorten the description of patterns arises because of the cumbersomeness of  $F_k(x)$  due to the increase in the number of latch functions, which are formed according to the number of training points. The number of latches can be reduced by selecting training points in such a way that the corresponding latches do not intersect, and on the other hand, by covering several latches with one function with a larger value of  $\Delta x_i = \frac{x_{imax} - x_{imin}}{2}$ ,  $i = \overline{1, m}$ .

Due to the random nature of the training points location, the second way is more effective. The idea of covering latch functions is as follows: if a certain area is described by a set of latch functions, as shown in Fig. 5, then this description can be replaced by one latch function (bold lines in Fig. 5). Based on expressions (7), (13) we get:

$$\begin{aligned}
 &P(x_1, x_2, x'_1, x'_2, x''_1, x''_2) + P(x_1, x_2, x'_1, x'_2, x'''_1, x'''_2) + \\
 &+ P(x_1, x_2, x''_1, x''_2, x'''_1, x'''_2) + P(x_1, x_2, x'_1, x'_2, x'''_1, x'''_2) = \\
 &= P(x_1, x_2, x'_1, x'_2, x'''_1, x'''_2) \qquad (14)
 \end{aligned}$$

It is obvious that while providing a given accuracy of approximation of the function,  $F_k(x)$  a partial coverage or “overlapping” is acceptable, as shown in Fig. 4. b, c.

The task of reducing the description can be reduced to covering the latch functions of the training points of each class with latch functions with large values of  $\Delta x_i$ .

One of the possible description reduction algorithms is as follows [11.]. Fig. 6 shows the area  $S_k$ . Let's single out rectangular area  $S_{n(0,1)} \supset S_k$ . This area is described by the latch function  $P_{(0,1)}$ . Let's consider the area  $S_k$  belonging to  $S_{n(0,1)}$ , that is

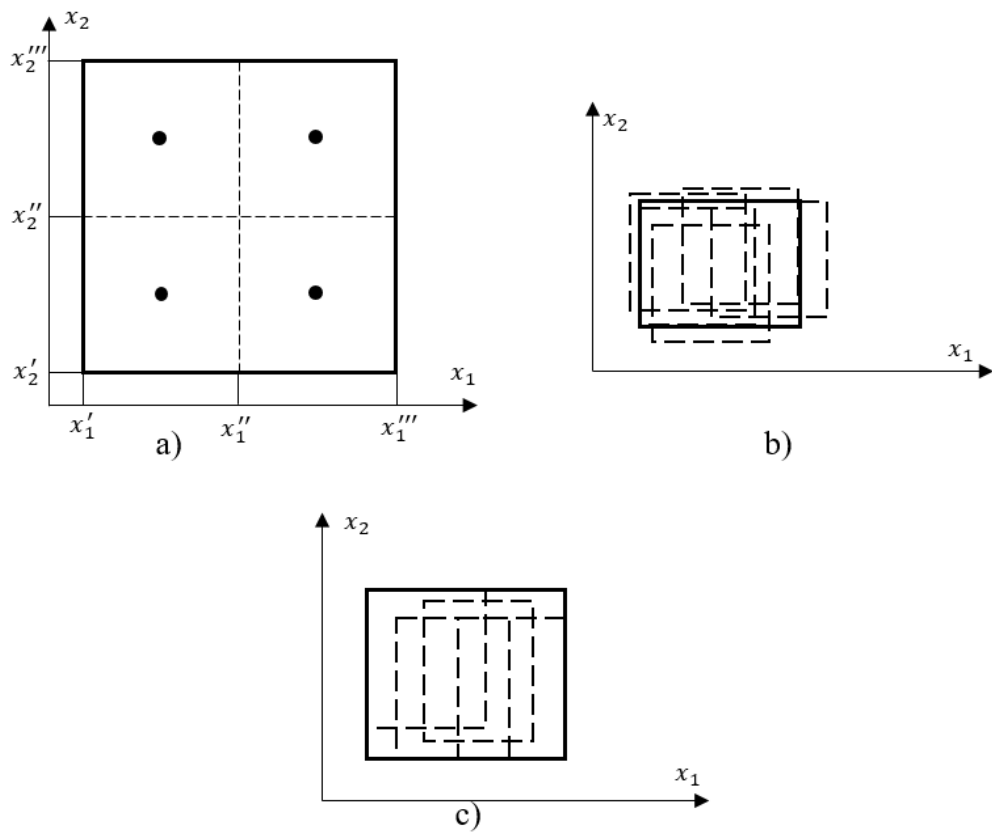

**Figure 5 – Coverage of the neighborhoods of training points: a – accurate coverage; b – partial coverage; c – overlap**

$\bar{S}_k = S_{n(0,1)} \setminus S_k$ . It is described by the function:

$$\text{sign}(F_k(x)) \quad \bar{F}_k(x) = P_{(0,1)} - a \cdot \quad (15)$$

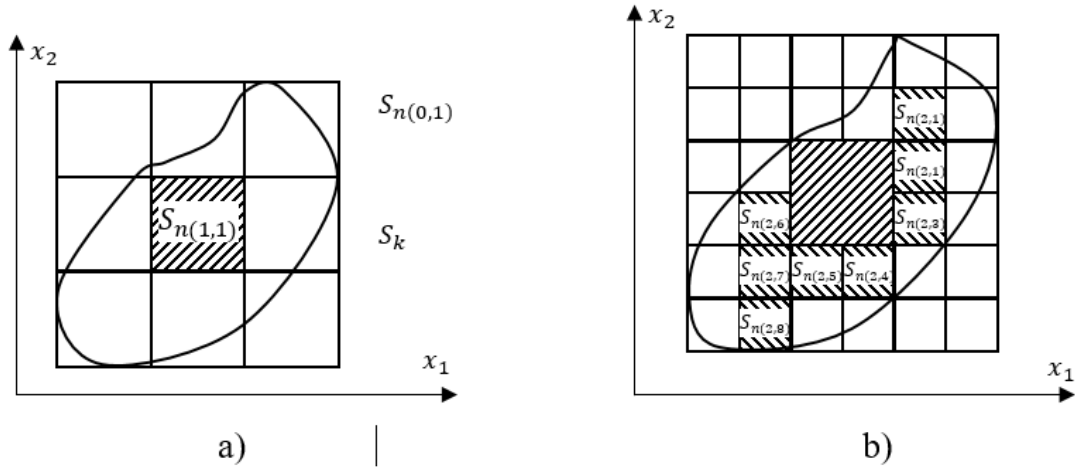

**Figure 6 – Stages of reducing the description of classes: a – the first stage; b – the second stage**

It's obvious that:

$$\bar{F}_k(x) = \begin{cases} 0 & \text{when } d \in S_k, d \in S_{n(0,1)} \\ a & \text{when } d \notin S_k, d \in S_{n(0,1)} \end{cases} \quad (16)$$

Here  $d$  is some point of the attribute space.

The description reduction algorithm includes the following operations.

1. The area  $S_{n(0,1)}$  is divided into subdomains with the division base  $\chi_1$ .
2. Those subdomains that do not intersect  $S_k$  are described by latch functions and the sum of these functions is found. In example (6) this is the area  $S_{n(1,1)}$ . Therefore the amount  $\sigma_1 = P_{(1,1)}$ .

3. Subdomains not described by the sum  $\sigma_1$  are divided with the division base  $\chi_2$ . The newly formed subdomains that do not intersect  $\bar{S}_k$  are described by latch functions, which are then added to the sum:

$$\sigma_2 = \sigma_1 + \sum_{\gamma=1}^8 P_{(r,\gamma)} \quad (17)$$

This procedure is repeated until the specified accuracy of the approximation of the function  $F_k(x)$  by the sum  $\sigma_\mu$  is reached.

The number of stages  $\mu$  is determined by the value selection strategy  $\chi_\lambda, \lambda = \overline{1, \mu}$  and the specified accuracy of the description  $\theta$ . In general:

$$\sigma_\mu = \sum_{\lambda=1}^\mu \sum_{\gamma=1}^{D_\lambda} P_{(\lambda,\gamma)} \quad (18)$$

The author has showed that this algorithm allows us to obtain a description whose

rank is no greater than the rank of the original description built on the basis of training points. In this case, to ensure the specified accuracy of approximation, the following inequality must be satisfied:

$$\Delta x_i^{(kj)} \leq \frac{x_{imax} - x_{imin}}{2\theta} \tag{19}$$

where  $\Delta x_i^{(kj)}$  is the limit of the admissible value  $i$  – a feature in the neighborhood  $j$  – a point of  $k$ -class;  $x_{imax}, x_{imin}$  – maximum and minimum values of  $i$ -characteristic.

### 1.3.2 Predicate model transformations by combining boundary sub-domains

Reviewed algorithm of description reduction was developed in work [2]. The solution to the problem of limiting structural changes in the predicate model is proposed to be carried out on the basis of the invariance of the number of parameters of the hyperparallelepiped to the size (volume) of the region it defines in the feature space. Set of randomly arranged hyperparallelepipeds  $k$ -patterns can be represented in the form of ordered hyperparallelepipeds, differing in size (Fig. 7). Hyperparallelepipeds located on the boundary of the pattern will have the smallest dimensions, since they determine the accuracy of the separating function  $\bar{F}_k(x)$ . On Fig. 7 they are shaded.

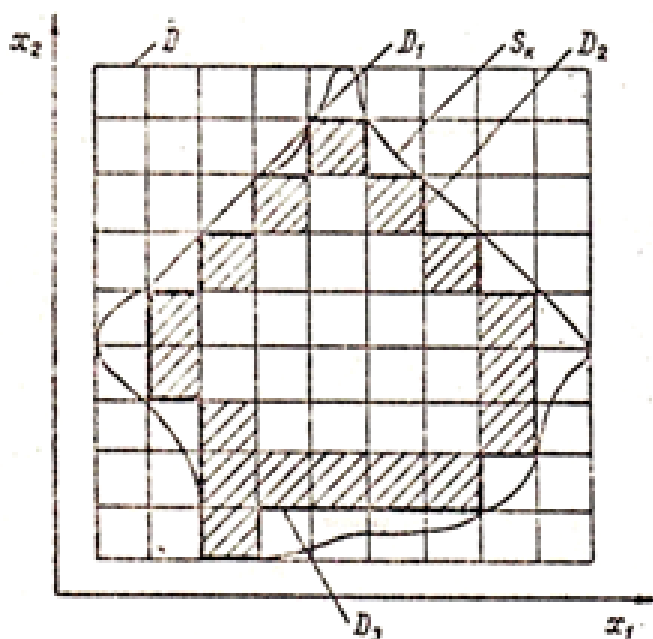

**Figure 7 - Location of Boundary Subareas**

If we unite the shaded boundary subdomains in the direction of one of the feature axes, for example  $x_1$ , we will get subdomains that differ in geometric dimensions and completely describe the pattern. Thus, the union of subdomains  $D_1$  and  $D_2$  is of interest,



since the resulting subdomain  $D_{12}$  includes, in addition to  $D_1$  and  $D_2$ , one more internal subdomain of the image  $S_k$ . Combining subdomains  $D_1$  and  $D_3$  into subdomain  $D_{13}$  will simultaneously describe four more internal subdomains.

It is easy to see that the combined subdomains differ only in the parameters of one projection. This allows us to propose a simple condition according to which two boundary subdomains are to be united if all internal subdomains between them belong to the pattern  $x_{j\min}^1 = x_{j\min}^2$ ;  $x_{j\max}^1 = x_{j\max}^2$  at  $j = \overline{1, n}$ ;  $j \neq r$ , where  $x_{j\min}^1, x_{j\min}^2, x_{j\max}^1, x_{j\max}^2$  are the parameters of the function (14) describing the two subdomains to be combined;  $r$  is the number of the feature axis in the direction of which the merging is performed. For the resulting subdomain, the unknown minimum and maximum value of the  $m$ -feature is defined as  $x_{m\min}^{12} = \min\{x_{m\min}^1, x_{m\min}^2\}$ ;  $x_{m\max}^{12} = \max\{x_{m\max}^1, x_{m\max}^2\}$ .

It is obvious that the considered association of boundary subdomains does not lead to a change in the location of the pattern in the attribute space, since the boundary domains do not change their location – they only merge with oppositely located boundary subdomains. This transformation of the pattern is identical. It can be performed immediately when the previously mentioned contradiction of the second kind occurs. Then the complication of the structure of the model (14) is not required.

It should be noted that the number of enlarged subdomains obtained as a result of merging is less than the number of boundary subdomains. These associations can be continued in the remaining  $n - 1$  directions. If you change the merging sequence along the attribute axes, you can get  $n!$  separating functions, from which the minimum in terms of the number of constituent subdomains is selected.

The search for the minimum number of subdomains can be implemented as follows [12]. A lot of technological situations that are given by predicates (14) are grouped into a class according to the value of the control criterion. Each class is defined by the disjunction of predicates. The choice of such a model assumes the ordering of its elements in the form of a two-dimensional table. Moreover, values  $X_{j\min}^{pl}$ ,  $X_{j\max}^{pl}$  are placed in its columns and each row corresponds to a certain predicate.

It is not difficult to see that the columns of such a table will have different names and be homogeneous; all rows are unique and have the same structure. The order in which rows are traversed is not essential and only affects the speed of access to each of them. Taking into account that the information in the columns is atomic, it can be concluded that this table satisfies the conditions and constraints that allow it to be considered a relation – a relational data model [13]. The ordinal number of the tuple



in the relation (row of the table) uniquely identifies the current technological situation. The set of attributes (columns of the table) defines the schema of the relation. It is clear that there set of relations  $M_k$ , each of which describes a certain class of technological situations, completely determines the model of the technological process. Here  $k = \overline{1, q}$ , where  $q$  is the number of relations.

Operations on relations are determined by  $\alpha$ -algebra. Let's consider the application of  $\alpha$ -algebra for implementing the procedures of the proposed minimization algorithm.

Minimization algorithms are based on two subdomains  $D_1$  and  $D_2$  combined in factorial space (Fig. 8). The tuples of relation, that define these subdomains differ in the values of two attributes  $x_{1\min}, x_{1\max}$  ( $x_1$  is the characteristic axis along which the combination of subdomains takes place). Extracting the specified tuples  $D_1$  and  $D_2$  is achieved by the filtering operation. In order to obtain of a tuple  $D_{12}$ , which designates the combined area  $D_{12}$ , at first it's necessary to decompose the relation  $D_1$  into a relation  $D_{1MX}$  without an attribute  $x_{1\min}$  and a relation  $D_{1MN}$  without an attribute  $x_{1\max}$ ; and a relation  $D_2$  should be decomposed into a relationship  $D_{2MN}$  with a single attribute  $x_{1\min}$  and a relationship  $D_{2MX}$  with a single attribute  $x_{1\max}$ . This decomposition can be achieved through the operation of projection. Subsequently, by performing the Cartesian multiplication  $D_{1MX} \otimes D_{2MN}$  and  $D_{1MN} \otimes D_{2MX}$ , two tuples of relation  $D_{12}$  with a complete set of attributes are formed, from which the desired tuple  $D_{12}$  is extracted by filtering under following condition  $x_{1\min} < x_{1\max}$ .

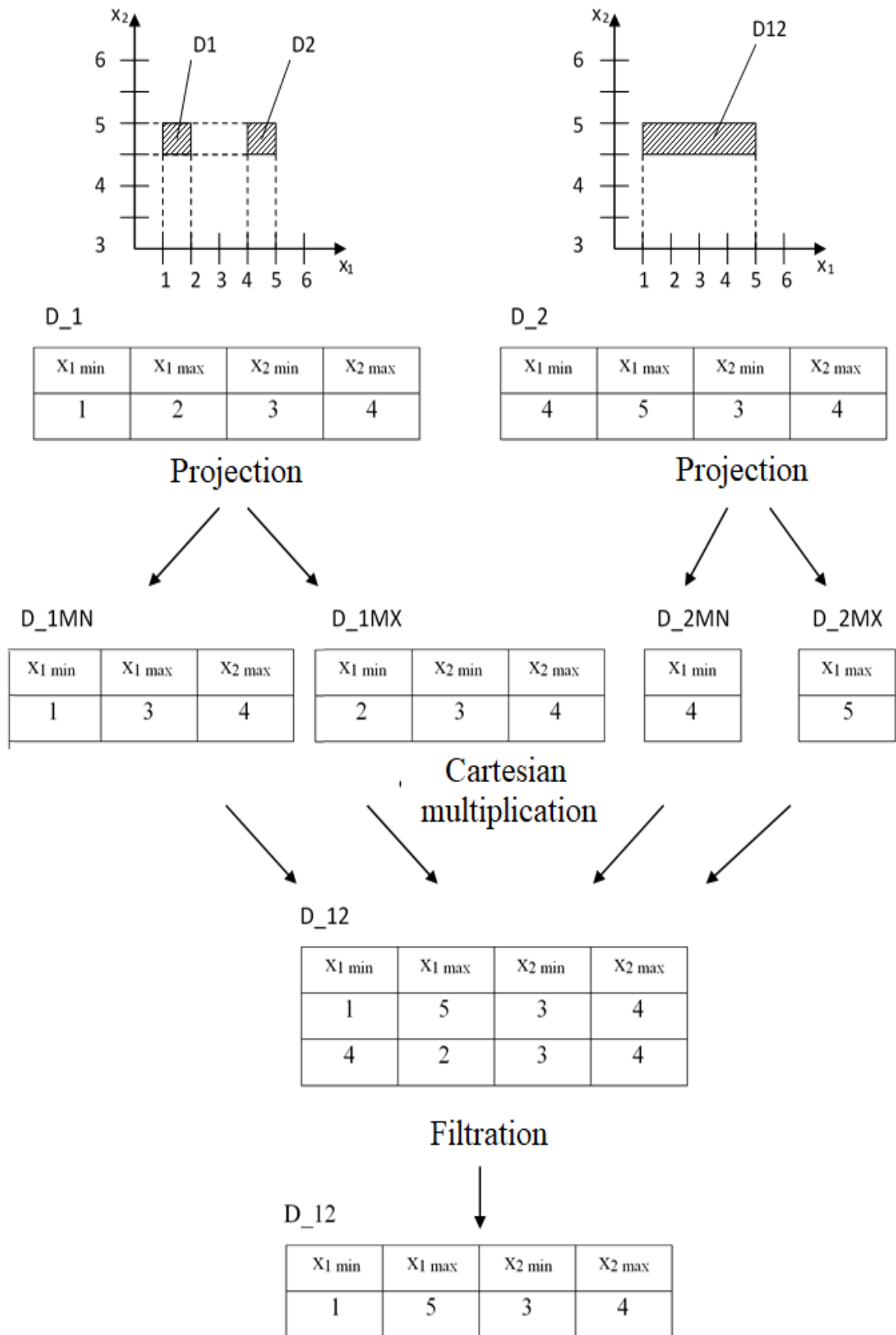

**Figure 8 – The determination of the tuple defining the combined area**



### 1.3.3 Encoding of the predicate model elements

Often there is a need to reduce the dimension of the vector describing the situation without losing information about the object. A special case of such a reduction is the transition from a vector to a scalar; that is, the transformation of a description of a situation by a set of numbers into an adequate description with just one number.

In [14] a method of convolutional Ks-transformation is proposed, which allows representing the technological situation in the form of an integer scalar. It can include both continuous and discrete variables.

In this case, the fact is used that variables, which are physically continuous quantities, can be discretized without reducing their information content due to limited, and often very low, measurement accuracy.

Let the situation at the facility be described by the vector  $P = (p_1 p_2 p_3 \dots p_i \dots p_n)$ , where  $p_i$  are the controlled variables of the process,  $i = \overline{1, n}$ .

In general case, the measurement accuracy of each of the elements allows dividing the full measurement range into its own number of equal discrete intervals (subranges)  $m_i, i = \overline{1, n}$ .

Let's assume that a vector of the number of subranges  $M = (m_1 m_2 m_3 \dots m_i \dots m_n)$  is given. We renumber all subranges of each variable in the direction from the lower limit of the full range to the upper one, as shown in Fig. 9.

Then the specific value of any variable can be approximately represented by the number of the subrange in which it falls (point A in Fig. 9). This establishes a correspondence of the following form  $P = (p_1 p_2 p_3 \dots p_i \dots p_n) \Rightarrow J = (j_1 j_2 j_3 \dots j_i \dots j_n)$ , where  $j_i$  is the number of the subrange in which the value of the variable  $p_i$  falls.

A vector  $J$ , if we consider its elements as digits of a number with base  $q$ , and  $q = j_n + 1$ , can be represented as a number by performing the transformation:

$$Ks = \sum_{i=1}^n j_i \cdot q^{n-i} \quad (20)$$

The reverse transition from Ks to  $J$  (reverse Ks- transformation) is performed according to the expression:

$$j_i = \text{mod} \left( \left[ \frac{Ks}{q^{n-i}} \right], q \right) \quad (21)$$

It is easy to see that the considered encoding method and description reduction algorithm imply splitting the feature (factorial) space into intervals  $\Delta x_i$  determined by the required accuracy of the image description. These areas are numbered in the direction of increasing  $i$ -th factor.

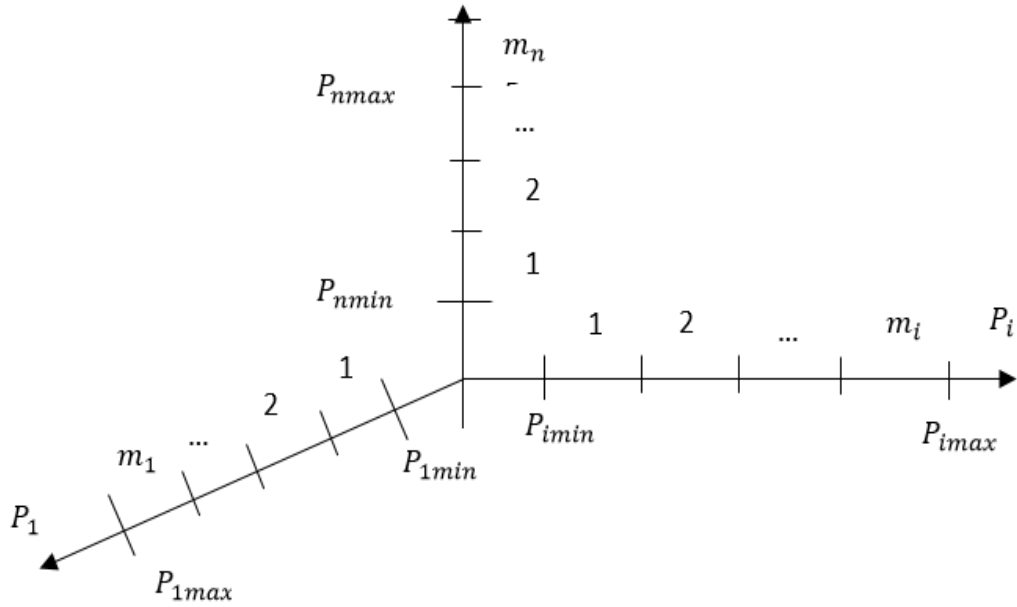

**Figure 9 – Discretization of variables**

As a result, elementary spaces are formed, the positions of which are uniquely determined by the numbers of the corresponding intervals, for example, intervals 5, 2 for the subdomain  $D_0$  (Fig. 10). The specified numbers and form an n-dimensional vector subject to convolution to a scalar according to the formula (20).

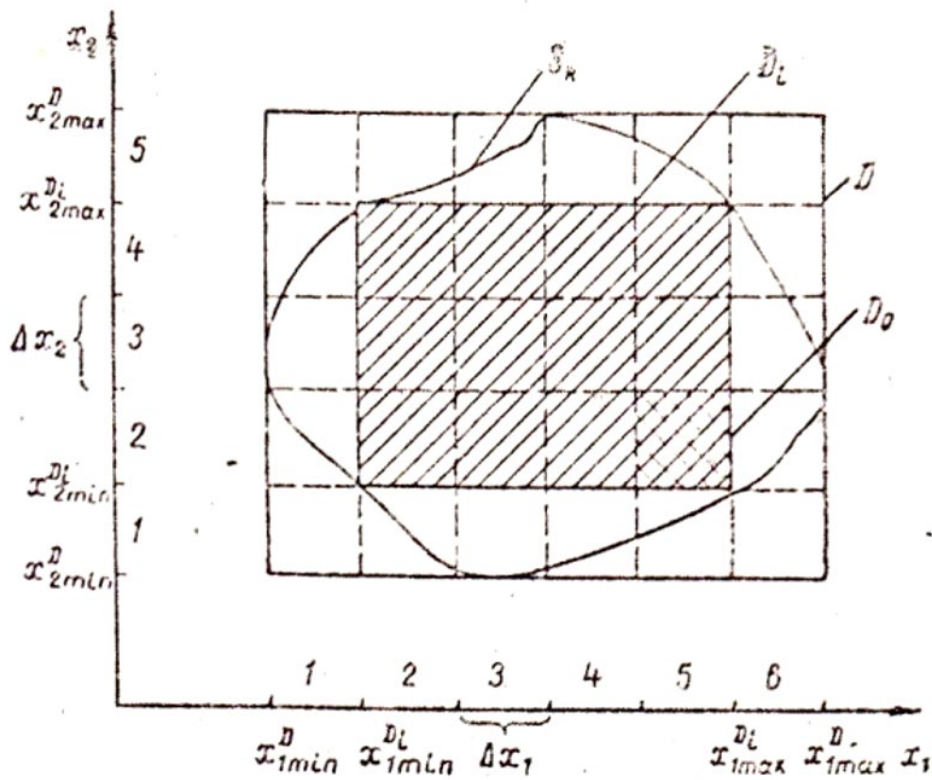

**Figure 10 - Encoding of large area**



Obviously, the projections obtained as a result of enlargement of a subdomain (for example,  $D_1$ ) cannot be represented as an n-dimensional vector, because each of them includes several intervals  $\Delta x_i$ , and the number of these intervals for each factor is generally different.

We will represent each projection of the specified subdomain with the numbers of two intervals  $\Delta x_j$  [2] that define its boundaries. Then any subdomain in the factor space can be represented by a 2n-dimensional vector  $\vec{B}(b_{1\min}, b_{2\min}, \dots, b_{n\min}, b_{1\max}, b_{2\max}, \dots, b_{n\max})$ , where  $b_{1\min}, \dots, b_{n\min}, b_{1\max}, \dots, b_{n\max}$  are the numbers of intervals that determine the minimum and maximum boundaries of the subdomain. For example, for a subdomain  $D_1$ , the vector is  $\vec{B} = \{2, 2, 5, 4\}$ . Having performed the encoding transformation (20) of this vector, we obtain a scalar that completely determines the enlarged subdomain.

The boundaries of the projections of the elementary subdomain are determined by the same interval  $\Delta x_j$ . Therefore, when encoding them, the following equality is obvious:  $b_{j\min} = b_{j\max} = b_j, j = \overline{1, n}$ . It should be noted that if an elementary subdomain is an integral part of a large one (for example,  $D_0$  and  $D_1$ ), then the numbers of intervals that determine the boundaries of their projections are interconnected by the relation  $b_{j\min}^i \leq b_j^0 \leq b_{j\max}^i, j = \overline{1, n}$ .

Having encoded all subdomains of the minimum separating function obtained at the first stage by means of the way mentioned above, the separating surface can be represented as a logical sum of one-dimensional numbers or two-dimensional vectors:

$$F_{min}^{total} = \sum_{\gamma=1}^{k_{min}} K_{\gamma}$$

Transition from coding numbers  $K_{\gamma}$  to the vector  $\vec{B}_{\gamma}(\vec{B}_{\gamma}^1, \vec{B}_{\gamma}^2)$  is carried out according to the formula (21), and the transition to the physical dimensions of the factor space of the pattern is carried out according to:  $x_{j\min} = (b_{j\min} - 1)\Delta x_j + x_{j\min}^D$ ;  $x_{j\max} = b_{j\max}\Delta x_j + x_{j\min}^D$ , where  $x_{j\min}^D$  is the minimum value of the j-th factor.



## 1.4. The choice of AM protection means on the basis of the predicate model "electrical network – asynchronous motor"

The decision on the economic feasibility of choosing a specific technical protection option (or rejecting it) depends on the values of several value (input technical and economical ones): sinusoidal distortion coefficient  $K_u$ , coefficients of individual harmonic components  $K_{u(m)}$  ( $m = 7$ ), negative sequence coefficient  $K_{2u}$ , zero sequence coefficient  $K_{20}$ , costs of technical means of protection  $C_j$  ( $i = \overline{1, r}$ , where  $r$  is the number of different types of protection devices).

The coefficients  $K_u$ ,  $K_{u(m)}$ ,  $K_{2u}$  and  $K_{20}$  depend on the patterns of changes in linear voltages in the electric network and the modes of operation of the asynchronous motor [15].

To determine the characteristics of the linear voltages of the electrical network of the workshop and asynchronous motors in real time, a software and hardware complex, shown in Fig. 11, has been developed. The hardware part of the complex is based on a programmable logic controller (PLC) VIPA System 200 V. The PLC is a module for remote input of analog signals.

The software part ensures the organization of computing processes and the organization of a human-machine interface using a personal computer and is based on the HMI/SCADA system Zenon Supervisor 7.0. Interaction between a programmable logic controller and a personal computer with a software package is implemented using the Ethernet interface.

Current values of linear voltages and motor parameters are displayed on the personal computer screen and saved for further processing. The proposed complex allows simultaneous research of all motors operating in the workshop.

Technical and economical quantities have some deviations, due to either the accuracy of measurement (for technical quantities) or to the economic situation (for values) and vary within a certain range. This allows us to present the energy-economic model of AM as a sum of predicates, which will take a specific form:

$$Z_{\text{ЭМ}}[\vec{X}, \vec{C}] = \bigvee_{p=1}^q \bigvee_l^{\lambda_p} Z_{p,l}[\vec{X}, \vec{C}], \quad (22)$$

Where

$$Z_{p,l}[\vec{X}, \vec{C}] = 2^{-n} \prod_{j=1}^n \{1 + \text{sgn}[(X_j - X_{jmin}^{pl})(X_{jmax}^{pl} - X_j)]\} + 2^{-r} \prod_{j=1}^r \{1 + \text{sgn}[(C_j - C_{jmin}^{pl})(C_{jmax}^{pl} - C_j)]\} \quad \vee - \text{the logical operation of disjunction.}$$



Here :  $q$  is the number of classes (ranges) of total damage from the introduction of a specific protective measure or their combinations;  $\lambda_p$  is the number of predicates defining the  $p$ -range;  $n$  and  $r$  are the number of technical and cost values, respectively;  $X_{jmin}^{pl}$ ,  $X_{jmax}^{pl}$ ,  $C_{jmin}^{pl}$ ,  $C_{jmax}^{pl}$  are model constants.

The formation of predicate parameters and their combination into classes can be carried out in the course of training the model according to the criterion of minimum economic losses from the use of technical means of protecting AM (or their absence):

$$E_{loss} \rightarrow \min, \tag{23}$$

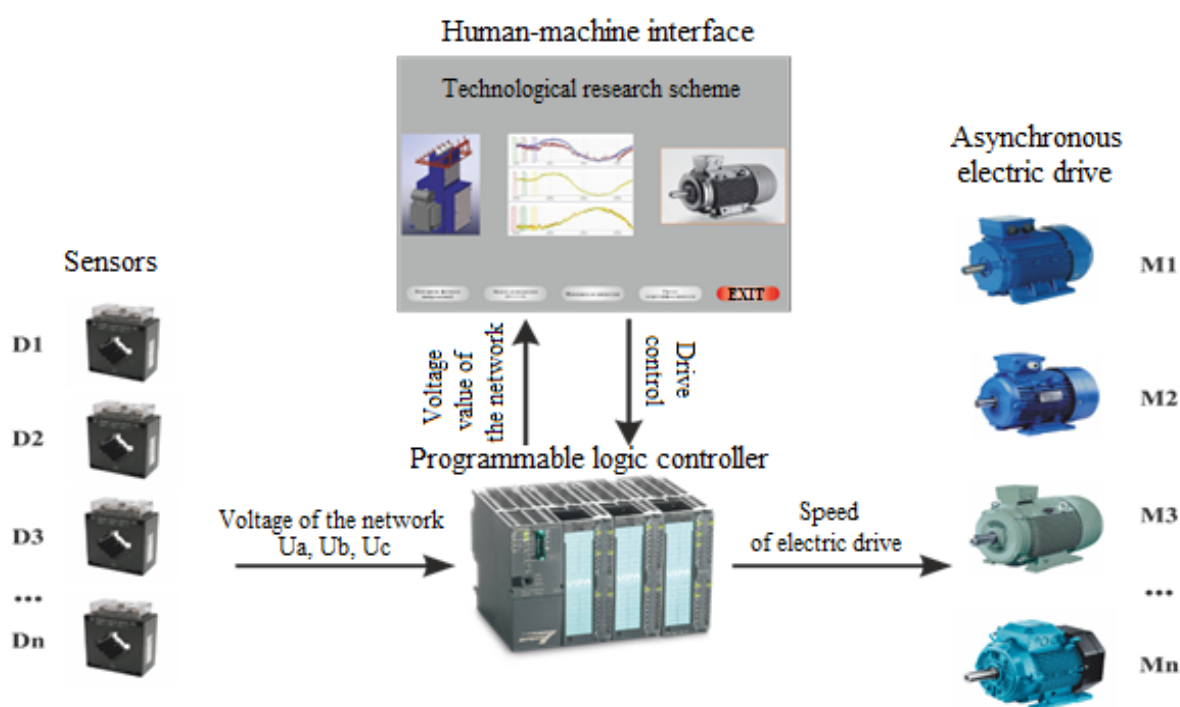

**Figure 11 – The structural diagram of the system for researching the electrical network and asynchronous motors**

During the training process for recognition based on elements of a selected sample of input variables, it is necessary to partition the factorial space into two classes:  $M_1$ , if  $E_s < E_{pot}$  and  $M_2$ , if  $E_s > E_{pot}$ , by setting various criteria  $E_{pot}$  in the interval  $E_{pot.max} \div E_{pot.min}$ . If the value of the criterion is changed with an interval  $\Delta E_{pot} = \frac{(E_{pot.max} - E_{pot.min})}{q}$ , then we will obtain  $q$  hypersurfaces separating classes, which, in accordance with the method of analytical description by methods that allow the division of the factor space into elementary subdomains, can be specified in the form of predicate equations (22). Here:  $\Delta E_{pot}$  is permissible deviation of economic losses



from the calculated value.

The model is trained on the basis of a computational experiment, the structural diagram of which is shown in Figure 12. During the experiment, random sequences of input values are formed in the block for the formation of realizations (BFR) within the specified limits.

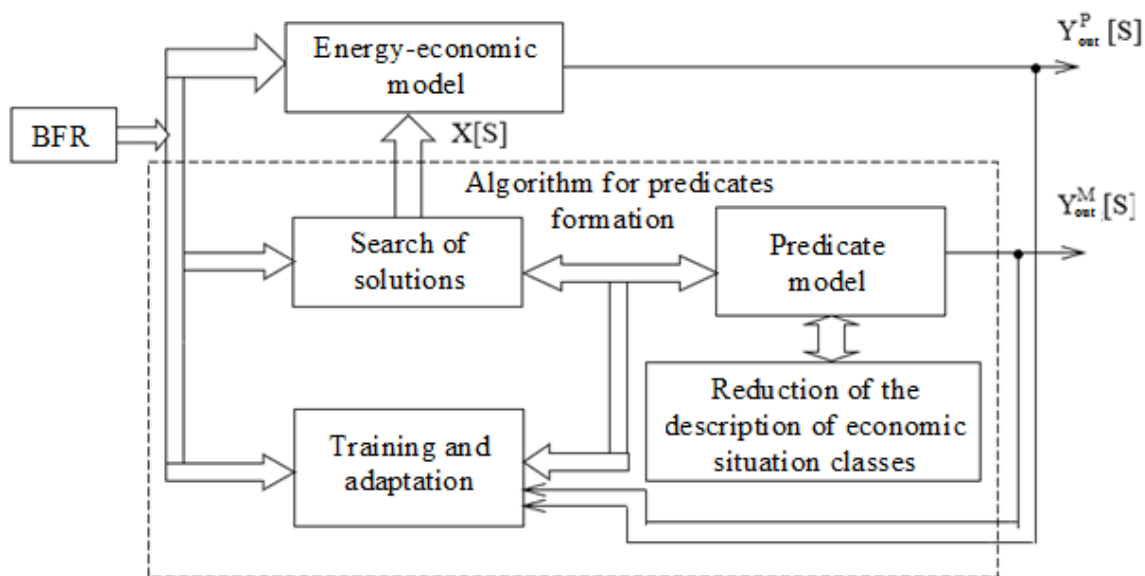

Figure 12 – Structural diagram of the predicate formation model

In the "Energy-Economic Model" block, the calculation of economic losses from the use (or refusal to use) of protective equipment for electric drives in power networks with low-quality electricity is carried out. Table. 1 shows the calculation formulas for losses determination according to [16].

Table 1 – Stages of economic losses calculation

Stage number	Computing subunit	Output parameters		
		Designation	Calculation formula	Name
1	2	3	4	5
1	Voltage model in workshop networks	$K_U$	$K_U = \sqrt{\sum_{n=2}^{40} U_n^2} \cdot \frac{100}{U_{iii}}$	Voltage sinusoid distortion coefficient
		$K_{U(n)}$	$K_{U(n)} = \frac{U_n}{U_{HOM}} \cdot 100$	Individual harmonic constituent's coefficient
		$K_{2U}$	$K_{2U} = \frac{A_2}{A_1}$	Reverse sequence coefficient
		$K_{20}$	$K_{20} = \frac{A_2}{A_1}$	Zero- sequence coefficient
1	2	3	4	5



2	Electromagnetic model of AM	$I_{Aeq}$	$I_{Aeq} = \sqrt{\frac{1}{N} \sum_{n=0}^N (i_{An})^2}$	Equivalent value of stator current (calculated for each phase)
		$I_{Req}$	the same for the rotor current	The same for the rotor
		$\underline{I}_{Mn}$	$\underline{I}_{Mn} = \underline{I}_{cmam_n} + \underline{I}_{pom_n}$	Magnetization current
		$\Delta P_{m1}$	$\Delta P_{m1} = (I_{Aeq}^2 + I_{Beq}^2 + I_{Ceq}^2) R_{cma}$	Copper losses for stator
		$\Delta P_{m2}$	the same for the rotor	the same for the rotor
		$\Delta P_C$	$\Delta P_C = 3 \cdot I_M^2 \cdot R_C$	Steel losses
		$\Delta P_\Sigma$	$\Delta P_\Sigma = \Delta P_{m1} + \Delta P_{m2} + \Delta P_C$	Steel losses
		$P_1$	$P_1 = U_A I_A + U_B I_B + U_C I_C$	Consumed active power
		$Q_1$	$Q_1 = \sqrt{S_1^2 - P_1^2}$	Consumed reactive power
		$S_1$	$S_1 = U_{Aeq} I_{Aeq} + U_{Beq} I_{Beq} + \dots + U_{Ceq} I_{Ceq}$	Consumed complete power
		$P_2$	$P_2 = \omega_{cp} \cdot M_{cp}$	Shaft power
		$\eta$	$\eta = \frac{P_2}{P_1}$	Efficiency
		with $\cos\varphi$	$\cos\varphi = \frac{P_1}{S_1}$	Power coefficient (taking distortion into account)
		3	AM thermal model	$THD_I$
$THD_T$	the same for the moment			The same for the moment
$\tau(t)$	$\tau_k = \tau_{(k-1)} + 1/C (\Delta P - A\tau_{(k-1)})$			Tme dependence of temperature exceedance
$\tau_{cf}$	$\tau_{cp} = \frac{1}{M} \sum_k \tau_k$			Average insulation temperature
4	Model of economic damage	$\acute{\alpha}$	$\acute{\alpha}' = \frac{1}{T_{II}} \sum_n (\Delta\tau_n \cdot t_n)$	Equivalent duration of AM operation with overheating
		$T$	$T = T_H \cdot e^{-\beta \cdot \acute{\alpha}'}$	Isolation service time
		$E_{sum}$	$E_{sum} = \Delta P_{\Sigma add} \cdot C \cdot T_{work}$	Additional damage
5	Determination of parameters for the selected technical protection device	$E_{year}$	$E_{year} = E_{sum1} - E_{sum2} - e \cdot K$	Annual economic damage
		C1	ss set to 1 mF	Capacity in the barrier filter
		L1	$L_1 = \frac{1}{\omega_r^2 C}$	Inductance of the barrier filter
		C2	Is found iteratively	Capacity in the "star" part of the combined filter
		$E_{TS}$	Is determined separately	Price of technical funds

The elements of the predicate model are formed in the “Training and Adaptation”



block. In this case, the number of predicates of a fully defined model depends on the parameters of the input values and is determined by the formula:

$$K_q = \prod_{i=1}^n \frac{d_i}{\Delta x_i} \tag{24}$$

Here  $d_i$  and  $\Delta x_i$  are the range of change and step of variation of the  $i$ -input quantity. Table. 2 shows data on the parameters of input quantities when studying the operation of an AM with a power of 7.5 kW, operating under conditions of poor-quality electricity. As it follows from Table. 2 and (4)  $K_q = 1,664 \cdot 10^{13}$ . The calculation of such a number of predicates in acceptable time intervals is difficult.

**Table 2 – Parameters of AM input values**

No	Input value	Range of variation	Step of variation	Notes
1	Voltage sinusoid distortion coefficient	2-15%	0.5%	
2	Individual harmonic constituent's coefficient	0 - 10%	0.5%	first 7 harmonics
3	Reverse sequence coefficient	0 - 5%	0.1%	
4	Zero- sequence coefficient	0 - 5%	0.1%	
5	Price of technical funds	0-200000 UAH	2000 UAH	10 options of technical solutions

To overcome this difficulty, called the "curse of dimensions", in the course of training of predicate model, an accelerated learning algorithm was applied [17]. This algorithm allows you to include untrained regions of the factor space in the predicate model if simple conditions are met for two predicates from a certain class:

$$\begin{cases} X_{umin}^1 \leq X_{umin}^2 \\ X_{umax}^1 \geq X_{umax}^2, \text{ при } u = \overline{1, n}; u \neq 1' \end{cases} \tag{25}$$

where  $X_{umin}^1, X_{umax}^1, X_{umin}^2, X_{umax}^2$  are the parameters of the projections of the combined areas;  $u$  is the number of the feature axis of the factor space, in the direction of which the subdomains are merged.

In the "Predicate model" block, according to the generated values of the parameters of technical and economic quantities and the economic losses calculated according to the energy-economic model from the use of protective devices, the economic situation is formed in the form of predicates and is included in the  $p$ - class. The class number of the economic situation is determined by the formula:

$$p = \text{entier} | E_{pot} \times \Delta E_{pot}^{-1} | + 1 \tag{26}$$

It should also be noted that for the predicate model, an adaptation algorithm has



been developed. It allows predicate model to be refined due to the expansion of the fleet of technical means and changes in their costs. Refined p-class of economic situations is determined according to the algorithm considered in clause 2. And in the "Reduction of the description of economic situation classes" block, the description of patterns is minimized and subdomains are encoded in accordance with clause 3.

The determination of the best technical option for protecting the AM according to the predicate model is carried out on the basis of a recognizing static optimization algorithm in the "Search of solutions" block as follows. For current values of technical quantities, it is calculated  $Z_{\text{эМ}}[\vec{X}, \vec{C}]$  starting from the first class of economic ones  $p = 1$ , which corresponds to the minimum value of economic losses. If  $Z_{1l}[\vec{X}, \vec{C}] = 0$ , for all  $l = \overline{1, \lambda_1}$ , then the second class of economic situations is analyzed, etc. This procedure is carried out until for some  $p = c$  and  $l = Z_{cg}[\vec{X}, \vec{C}] = 1$ . Then, according to the value of the constants of the selected predicate, the financial costs and, accordingly, the chosen technical protection option are determined.

In [12] it is shown that the predicate equations (22) can be represented in the form of a relational data model. This makes it possible to describe the procedures for learning, adapting, minimizing and searching for optimal solutions based on a single mathematical apparatus which is  $\alpha$ -algebra. Taking into account that the relational models are supported by the DBMS, this approach to determining the best technical means of protecting the AM during its operation in conditions of low-quality electricity is easily implemented in a production environment.

The proposed approach was tested when choosing protection means for a 7.5 kW asynchronous motor operating during 80% of the operating cycle in conditions of low-quality electricity in the experimental workshop of JSC "Ukrspets servis". The research results are given in Table 3.

As can be seen form Table 3 – in order to protect this asynchronous motor, it is enough to use a passive LC-filter costing 2000 UAH. At the same time, annual economic losses will amount to  $E_{pot} = 3700$  UAH / year.



**Table 3 – Research results**

No	Input value	Technical parameter	Price	Notes
1	Voltage sinusoid distortion coefficient	2.5%	-	
2	Individual harmonic constituent's coefficient	1.5%	-	
		0.5%		
		0.5%		
		2.5%		
		0.5%		
		2.0%		
		2.0%		
3	Reverse sequence coefficient	2.3%	-	
4	Zero- sequence coefficient	1.5%	-	
5	Price of technical funds	-	2000 UAH	Passive filter

**Conclusions**

The method developed in the work for selecting economically feasible means of increasing the energy efficiency of an asynchronous motor and the algorithm for calculating the total economic damage when the latter operates in conditions of low-quality electricity allow us to make an economically sound decision on the choice of means of compensating for the negative impact of low-quality electricity on the technical and economic indicators of an asynchronous motor, which is made based on comparison of the amount of damage, the cost of the electric motor and the proposed technical means of protecting it.

The results of the research can be recommended for use in the learning process of students of the next Fields of knowledge: 14: Electrical engineering, specialties: 141 - Electrical power engineering, electrical engineering and electromechanics; 17- Electronics, automation and electronic communications, specialties: 172 - Electronic communications and radio engineering; and specialties: 174 – Automation, computer-integrated technologies and robotics.



## *Verweise / References*

### *Chapter 1.*

1. Yevheniia Kuznetsova, Vitaliy Kuznetsov, Mykola Tryputen, Alisa Kuznetsova, Maksym Tryputen, Mykola Babyak Development and Verification of Dynamic Electromagnetic Model of Asynchronous Motor Operating in Terms of Poor-Quality Electric Power (2019) Proceedings of the International Conference on Modern Electrical and Energy Systems, MEES 2019, pp. 350 - 353, DOI: 10.1109/MEES.2019.8896598
2. Tryputen M., Kuznetsov V., Kovzel M., Kovalenko V., Artemchuk V., Nadtochyi V. Minimization of the Description of Images in the Problem of Adaptive Control of Static Technological Objects (2021) Proceedings of the 20th IEEE International Conference on Modern Electrical and Energy Systems, MEES 2021, DOI: 10.1109/MEES52427.2021.9598651
3. Vitaliy Kuznetsov, Nikolay Tryputen, Yevheniia Kuznetsova Evaluating the effect of electric power quality upon the efficiency of electric power consumption (2019) 2019 IEEE 2nd Ukraine Conference on Electrical and Computer Engineering, UKRCON 2019 - Proceedings, pp. 556 - 561, DOI: 10.1109/UKRCON.2019.8879841
4. Kuznetsov V., Tryputen M., Kuznetsova Y., Babyak M., Artemchuk V., Kovzel M. Ways to Improve Power Quality under the Conditions of Industrial Enterprises (2020) Proceedings of the 25th IEEE International Conference on Problems of Automated Electric Drive. Theory and Practice, PAEP 2020, DOI: 10.1109/PAEP49887.2020.9240801
5. Tryputen M., Kuznetsov V., Kuznetsova A., Tryputen M., Kuznetsova Y., Serdiuk T. Improving the Reliability of Simulating the Operation of an Induction Motor in Solving the Technical and Economic Problem (2021) Advances in Intelligent Systems and Computing, 1247 AISC, pp. 143 - 152, DOI: 10.1007/978-3-030-55506-1\_13
6. Tryputen M., Kuznetsov V., Kuznetsova A., Kovzel M., Tryputen M. Developing Stochastic Model of a Workshop Power Grid (2020) Proceedings of the 25th IEEE International Conference on Problems of Automated Electric Drive. Theory and Practice, PAEP 2020, DOI: 10.1109/PAEP49887.2020.9240898



7. Kachan Yu.G. Adaptation of Image in the Production Situation Recognition Algorithm // Mechanization and Automation. - 1984. No. 1. - pp. 15 – 17.
8. Khorolsky V.P., Sirodzha I.B., Shvartser V.Ya. et al. // News of Universities. Mining Journal. 1969. - No. 10. - pp. 135 – 140.
9. Voronov V.A. The Method of Describing Technological Situations and Its Application in Process Management // Ore Enrichment. - 1982. - No. 2 - pp. 31 - 35.
10. Mishchenko V.A. The method of selective functions in nonlinear problems of control and management. - M.: Soviet Radio, 1973. - 184 p.
11. Voronov V.A. "Reduction of Image Descriptions in the Problem of Recognition in Ore Beneficiation Process Control" in "Mineral Processing." - 1982. - No. 3. - pp. 38 – 42.
12.  $\alpha$ -algebra in problems of improving the energy efficiency of asynchronous motors operating under poor power conditions" / Tryputen M.M., Kuznetsov V.V., Kuznetsova Ye.V., Tryputen M.M., Kuznetsova A.V. / Mining Electromechanics and Automation, 2019, No. 101, pp. 110-114.
13. Dribas V.P. Relational Database Models // Minsk: BSU - 1982 - 192 p.
14. Voronov V.A. One-dimensional numerical encoding of situations in automated control of technological processes" // Mineral Processing – 1984. – No. 4. – pp. 38-41.
15. Kuznetsov, V.V., Tryputen, M.M., Kuznetsov, V.G., Tryputen, M., Kuznetsova, A., Kuznetsova, Y. Choosing of asynchronous motor protection equipment in production environment (2020) IOP Conference Series: Materials Science and Engineering, 985 (1) DOI: 10.1088/1757-899X/985/1/012022
16. Kuznetsov V.V. "Means of Improving the Energy Efficiency of Asynchronous Motors Operating in Networks with Poor Power Quality: Abstract of the Candidate of Technical Sciences Thesis." - Ministry of Education and Science of Ukraine, State Higher Educational Institution "NGU," 2013.
17. Triputen N.M., Koba A.S. "Methodology and Results of Computational Research on the Predicate Model Identification Algorithm" // Mining Electromechanics and Automation. – 2000. – No. 64. – pp. 106-108.



SCIENTIFIC EDITION

MONOGRAPH  
WISSENSCHAFTLICHE FORSCHUNG UNTER MODERNEN  
BEDINGUNGEN DER INSTABILITÄT  
INNOVATIVE TECHNOLOGIE, VERKEHRSENTWICKLUNG,  
ARCHITEKTUR UND BAUWESEN

SCIENTIFIC RESEARCH IN MODERN CONDITIONS OF INSTABILITY  
INNOVATIVE TECHNOLOGY, TRANSPORT DEVELOPMENT,  
ARCHITECTURE AND CONSTRUCTION  
MONOGRAPHIC SERIES «EUROPEAN SCIENCE»  
BOOK 24. PART I

Authors:

Tryputen M. (1), Kuznetsov V. (1), Zhadanos O. (2), Proidak Y. (2), Derevyanko I. (2),  
Petrenko M. (2), Obodovych O.M. (3), Sydorenko V.V. (3), Tselen B.Y. (3),  
Stepanova O.E. (3), Rezakova T.A. (3), Semerak M.M. (4), Rymar T.I. (4),  
Sumakhina G.O. (5), Naumenko N.V. (5), Melnyk O.P. (6), Kuzmin O.V. (6),  
Niemirich O.V. (6), Mamchenko L.Y. (6), Dudarev I.M. (6), Lytovchenko O.M. (6),  
Kalinichenko T.V. (7), Cherkudinov V. (8), Zelenko Y. (8), Mysak I.V. (9, 10)

The scientific achievements of the authors of the monograph were also reviewed and recommended for publication at the international scientific symposium  
«Wissenschaftliche Forschung unter modernen Bedingungen der Instabilität '2023 /  
Scientific research in modern conditions of instability '2023»  
(November 30, 2023)

Monograph published in the author's edition

The monograph is included in  
*International scientometric databases*

500 copies  
November, 2023

Published:  
*ScientificWorld - Net Akhat AV*  
Lußstr 13,  
Karlsruhe, Germany



e-mail: [editor@promonograph.org](mailto:editor@promonograph.org)  
<https://desymp.promonograph.org>



