

**Oleh Voznyak<sup>1</sup>, Serhii Buriak<sup>2</sup>**

1. Lviv Polytechnic National University  
12, S. Bandery Str., Lviv, 79013, Ukraine

2. Ukrainian State University of Science and Technologies  
2, Lazariana Str., Dnipro, 49010, Ukraine

© O. Voznyak, S. Buriak, 2023

<https://doi.org/10.23939/tt2023.01.038>

## METHOD OF DETERMINATION OF THE RAILWAY ROLLING STOCK COORDINATES WITHIN THE TRACK CIRCUIT

***Summary.** This work aims to solve one of the essential problems in railway transport – control over the position of moving units within the race. A method of constant monitoring of the track circuit with a determination of the coordinate of the train shunt placement in the shunt mode of working is proposed to solve this problem. Since the model includes the primary parameters of the track circuit, which may change their values over time, it is suggested to determine them in another (normal) working mode of the track circuit.*

*Therefore, according to the proposed model, the secondary and primary parameters of the track circuit are first determined in the track circuit's normal work mode. Next, already in the shunt mode of its work, the obtained parameters are used to determine the coordinates of the moving unit.*

*According to this method, firstly, the work mode of the track circuit is determined, which consists in determining the state by its input impedance. This step is performed in two stages. In the first stage, based on the state of the track relay, the fact that the track circuit doesn't work in normal mode is verified. In the second stage, the shunt mode is separated from the control mode by the value of the track circuit input impedance.*

*In the shunt mode of the track circuit operation, the coordinate and, if necessary, the speed and acceleration of the moving unit located within the given track circuit are determined. In the normal mode of the track circuit line operation, the values of its secondary parameters are specified based on the measured values of current, voltage, and phase shift between them. This operation is performed to increase the precision of the speed and acceleration determination by solving an inverse problem. In the control mode of the track circuit operation, it is possible to determine the coordinates of damage. This method does not require a significant volume of calculations. It makes it possible to determine the secondary parameters of the track circuit and through them, the resistance of its insulation.*

*Using this method makes it possible to determine the distance and, if necessary, the speed and acceleration of a moving unit within the track circuit. The resulting parameters can be used for positioning moving rolling stock on runs between stations. The application of this method can also be useful in sections of the railway crossings approach to implement a fixed warning time. In addition, thanks to the use of the outlined model, in the control mode of the track circuit operation,*

is possible to determine the damage coordinate. It will make it possible to reduce the time spent on damage detection and elimination.

**Key words:** track circuits, input impedance, moving unit coordinate, movement parameters, safety improvement.

## 1. INTRODUCTION

In the railway automation and telemechanic systems on the railways of Ukraine, electric track circuits are used as a sensor of information about the movement of trains. They use rail lines as a sensitive element [1, 2]. Track circuits work in three main modes of operation [1, 3, 4]: normal, shunt, and control. The state of the track circuit, when the track circuit is in good condition and there is no rolling stock within its boundaries, corresponds to its normal mode. When the moving unit enters within the limits of the rail line, the track circuit switches to shunt mode. The injured state of the rail line corresponds to the operation of the track circuit in the control mode.

Methods and means of determining the train coordinate by controlling the electrical parameters of a track circuit are considered in works [5–14]. However, the dependence of the primary parameters of the track circuits on the resistance of the ballast insulation does not contribute to ensuring the necessary accuracy of these methods. Therefore, the task of the work is to improve a method of determining the mode of the track circuit operation and to develop a method of its insulation resistance determination.

One of the problems solved in this work is control over the process of railway vehicles' movement along the rail line. For this purpose, it is necessary to provide their coordinates in real-time determination. The track relay, which is turned on at the end of the track circuit, reliably copes with the detection of the normal mode. However, it is impossible to distinguish between shunt mode and control mode using a track relay. Therefore, scientists have been working on methods and tools that provide additional information about the mode in which the track circuit is currently operating [4, 6, 7, 8, 10, 15–20]. One of these approaches is the definition of operating modes based on the rail circuit characteristic parameters, which include voltages and currents at the beginning of the rail line, or their ratio, that is, the track circuit input impedance [5, 15–18, 20].

## 2. MATHEMATICAL MODEL OF THE TRACK CIRCUIT OPERATION MODES DETERMINING

It is necessary to set the parameters, which are used to obtain information about the state of the track circuit to determine a moving unit coordinate and speed in real-time, since each measured value is some of its characteristics. To determine a moving unit coordinate and speed, are made on each specific line measurement and its mathematical model is implemented, taking into its parameters. In modeling, the rail line is presented as a four-pole (long electric line) with evenly distributed parameters and a high level of various influences [3, 8, 10, 16–20]. In particular, by the rolling stock entry into the track circuit section or the rail strand integrity violation, there is a transition from the class of characteristic features of the normal mode to the class of features of the shunt or control modes. However, the change in the track circuit structural scheme is also influenced by other factors. For example, the ballast layer and sleepers' contamination, or the presence of various sleepers (wooden, reinforced concrete) within the rail line, and on electrified sections – the grounding of contact-line supports cause longitudinal asymmetry and heterogeneity of track circuits insulation resistance.

Fig. 1 shows the structural diagram of such measurements. Here, voltages and currents at the beginning of the rail line, or their ratio, i.e., input impedance, are used as informative attributes.

The measurement results constitute a set of attributes in each of the track circuit operating modes at different moments of time, which can be presented in the following form:

$$X_{i,j} = \{U_{1,i,j}, \varphi_{1,i,j}, I_{1,i,j}, \psi_{1,i,j}\}, \quad (1)$$

where  $U_{1,i,j}$ ,  $\varphi_{1,i,j}$  – amplitude and phase of the voltage at the input of the track circuit;  $I_{1,i,j}$ ,  $\psi_{1,i,j}$  – amplitude and phase of the current at the input of the track circuit;  $i = 1, 2 \dots n$  – the current number of the measured value;  $j = 1, 2, 3$  – the operation mode of the track circuit ( $j = 1$  – normal operation mode,  $j = 2$  – shunt operation mode,  $j = 3$  – control operation mode).

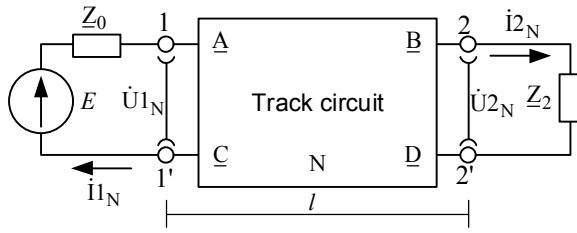

Fig. 1. Structural diagram of informative attributes measurements:  $\underline{Z}_0$  – the complex resistance of the current limiter at the input of the track circuit,  $\underline{Z}_2$  – the complex resistance of the load of the track circuit,  $\dot{U}_{1N}$ ,  $\dot{I}_{1N}$  – respectively, the voltage and current at the input of the track circuit,  $\dot{U}_{2N}$ ,  $\dot{I}_{2N}$  – respectively, the voltage and current at the output of the track circuit,  $N$  – a generalized four-pole of the entire rail line with the length  $l$ .

The relationship between voltages and currents at the input and output of the track circuit is expressed using the equation of states [3, 8, 18]:

$$\begin{cases} \dot{U}_{1j} = \dot{U}_{2j} \cdot \underline{A}_j + \dot{I}_{2j} \cdot \underline{B}_j \\ \dot{I}_{1j} = \dot{U}_{2j} \cdot \underline{C}_j + \dot{I}_{2j} \cdot \underline{D}_j \end{cases} \quad (2)$$

The coefficients of the rail four-pole track circuit in the normal mode of operation have the form [8, 18, 19]:

$$\begin{cases} \underline{A}_N = ch(\gamma \cdot l) & \underline{B}_N = \underline{Z}_w \cdot sh(\gamma \cdot l) \\ \underline{C}_N = \frac{1}{\underline{Z}_w} \cdot sh(\gamma \cdot l) & \underline{D}_N = \underline{A}_N = ch(\gamma \cdot l) \end{cases} \quad (3)$$

where  $l$  – track circuit length;  $\gamma$  – the coefficient of propagation of the signal by the track circuit:

$$\gamma = \sqrt{(r + j\omega L) \cdot (g + j\omega C)} = \sqrt{z/r} \quad (4)$$

$\underline{Z}_w$  – wave resistance:

$$\underline{Z}_w = \sqrt{\frac{(r + j\omega L)}{(g + j\omega C)}} = \sqrt{z \cdot r_i} \quad (5)$$

where  $r$ ,  $L$ ,  $C$ ,  $g$  – primary parameters of the rail line;  $\omega = 2\pi f$  – signal current frequency;  $z$  – resistivity of rails;  $r_i$  – insulation resistance of the track circuit, and on electrified sections – the equivalent resistance of the insulation of the track circuit and the grounding of the contact-line supports:

$$r_e = 0.5 \cdot r_i + \frac{0.5 \cdot r_i \cdot r_o}{0.5 \cdot r_i + r_o} \quad (6)$$

where  $r_o$  – grounding resistance of the contact-line supports, reduced to 1 km of rail line [3].

Fig. 1 shows that:

$$\begin{cases} \dot{U}_{1j} = \dot{E} - \dot{I}_{1j} \cdot \underline{Z}_0 \\ \dot{I}_{2j} = \frac{\dot{U}_{2j}}{\underline{Z}_2} \end{cases} \quad (7)$$

The system of equations (2), taking into equations (3) and (7), forms a mathematical model of the track circuit in normal operation mode.

From the system of equations (2), taking into equations (7), we obtain the voltage and current values at the input of the track circuit:

$$\dot{U}_{1j} = \frac{\dot{E}}{1 + \underline{Z}_0 \cdot \frac{\underline{C}_j \cdot \underline{Z}_2 + \underline{D}_j}{\underline{A}_j \cdot \underline{Z}_2 + \underline{B}_j}} \quad (8)$$

$$\dot{I}_j = \frac{\dot{E}}{Z_0 + \frac{A_j \cdot Z_2 + B_j}{C_j \cdot Z_2 + D_j}} \quad (9)$$

The values of voltage (8) and current (9) at the input of the track circuit, depending on its primary (secondary) parameters, make it possible to obtain a set of its attributes in normal  $N = f(\{\dot{U}_{1N}, \dot{I}_{1N}\})$ , shunt  $S = f(\{\dot{U}_{1S}, \dot{I}_{1S}\})$  and control  $K = f(\{\dot{U}_{1K}, \dot{I}_{1K}\})$  modes of operation.

The results of their division are sets of input impedance (resistance) of the track circuit in each of the operating modes  $Z_{1j} = \frac{A_j \cdot Z_{2j} + B_j}{C_j \cdot Z_{2j} + D_j}$ .

Since the track circuit, which is in the shunt mode of operation, is discretely affected by the shunt with resistance  $R_S$ , the generalized four-pole of the track circuit in the shunt mode  $S$  of operation is determined by:

$$\begin{bmatrix} \underline{A}_S & \underline{B}_S \\ \underline{C}_S & \underline{D}_S \end{bmatrix} = \begin{bmatrix} \underline{A}_{N1} & \underline{B}_{N1} \\ \underline{C}_{N1} & \underline{D}_{N1} \end{bmatrix} \times \begin{bmatrix} 1 & 0 \\ \frac{1}{R_S} & 1 \end{bmatrix} \times \begin{bmatrix} \underline{A}_{N2} & \underline{B}_{N2} \\ \underline{C}_{N2} & \underline{D}_{N2} \end{bmatrix}, \quad (10)$$

where  $[\underline{A}_{N1}, \underline{B}_{N1}, \underline{C}_{N1}, \underline{D}_{N1}]$  – coefficients of the four-pole  $N_1$  of the track circuit with a length of  $X$  km from the beginning of the track circuit line to the location of the train shunt  $R_S$ ;  $[\underline{A}_{N2}, \underline{B}_{N2}, \underline{C}_{N2}, \underline{D}_{N2}]$  – coefficients of the four-pole  $N_2$  of the track circuit with a length of  $(l-X)$  km from the location of the train shunt  $R_S$  to the end of the track circuit. The coefficients of four-poles  $N_1$  and  $N_2$  are determined as in the normal mode from (3) by substituting into the formula instead of the length  $l$  of track circuit the distances from the beginning of the track circuit to the location of the train shunt  $X$  and from the location of the train shunt to the end of track circuit  $(l-X)$ , respectively.

In the control mode of operation, the fracture of the rail thread is simulated by turning on resistance  $\underline{Z}_K$  at the point of rupture. The value of this resistance is determined from the expression:

$$\underline{Z}_K = E \cdot \underline{Z}_w \sqrt{1 + 2\rho} (cth(\gamma_1 \cdot l_1) + cth(\gamma_1 \cdot l_2)), \quad (11)$$

where  $l_1$  and  $l_2$  – sections of the track circuit to the left and right of the place of the cliff, and are  $(X)$  and  $(l-X)$ , respectively;  $\rho$  – the coefficient of surface conductivity, which characterizes the ratio between the components of insulation resistance;  $E$  – the characteristics of the components of the total resistance of the rails (constant of the earth tract), which depends on the frequency of the signal current;  $\gamma_1 = \frac{E \cdot \gamma}{\sqrt{1 + 2\rho}}$  – coefficient of propagation of the wave through the ground layer of the track circuit;  $\gamma$  – signal propagation coefficient by track circuit;  $\underline{Z}_w$  – wave resistance of the track circuit.

Since the track circuit, which is in the control mode of operation, is discretely affected by a section in the form of a rail thread fracture with a finite resistance value  $\underline{Z}_K$ , the generalized four-pole of the track circuit in the control mode of operation  $K$  is determined by:

$$\begin{bmatrix} \underline{A}_K & \underline{B}_K \\ \underline{C}_K & \underline{D}_K \end{bmatrix} = \begin{bmatrix} \underline{A}_{N1} & \underline{B}_{N1} \\ \underline{C}_{N1} & \underline{D}_{N1} \end{bmatrix} \times \begin{bmatrix} 1 & \underline{Z}_K \\ 0 & 1 \end{bmatrix} \times \begin{bmatrix} \underline{A}_{N2} & \underline{B}_{N2} \\ \underline{C}_{N2} & \underline{D}_{N2} \end{bmatrix}, \quad (12)$$

where  $[\underline{A}_{N1}, \underline{B}_{N1}, \underline{C}_{N1}, \underline{D}_{N1}]$  – coefficients of the four-pole  $N_1$  of the track circuit with a length of  $X$  km from the beginning of the track circuit line to the place of the rail thread fracture  $\underline{Z}_K$ ;  $[\underline{A}_{N2}, \underline{B}_{N2}, \underline{C}_{N2}, \underline{D}_{N2}]$  – coefficients of the four-pole  $N_2$  of the track circuit with a length of  $(l-X)$  km from the place of the rail

thread fracture  $Z_K$  to the end of the track circuit. These coefficients are determined in the same way as in the track circuit shunt operation mode.

A mathematical model was implemented in the computer algebra system Mathcad 15 to determine and study the areas of the existence of characteristic signs and the formation of attributes of rail line states in normal, shunt, and control modes using the classical approach of track circuit modelling [3, 8, 10]. Also, the model was implemented in the development environment for the visual programming language of National Instruments LabVIEW 2012. The simulation was carried out in the normal, shunt, and control modes of the track circuit operation, taking into account the resistance of the track circuit insulation and for electrified areas – the equivalent resistance of the track circuit insulation and the grounding of the contact-line supports. In the shunt and control modes of operation, the simulation was carried out, taking into account the coordinates of the shunt placement (shunt mode) or the break of the track circuit (control mode). At the same time, a shunt or an equivalent resistance of a track circuit break was put to its end (from the relay side). The input impedance of the track circuit was also determined, in addition to determining the input voltage and current at each step.

Since the voltage and current at the input of the track circuit, and its input impedance, are complex values, it is appropriate to consider the behavior of each of their components, namely the module (absolute value), argument (phase), real and imaginary parts. However, as stated in the work [18], the most appropriate value for determining the coordinate of the train within the track circuit is the component of the values' module. The dependencies of the remaining components of the voltage, current, and input impedance of track circuit complex values have a much more complex nature of dependence on the coordinate, which can contribute to ambiguities in the perception of measurement results. In addition, the usage of real and imaginary parts of complex values is also associated with the complexity of function models and the increase in calculation errors due to additional transformations of numbers.

### 3. DETERMINATION OF THE MOVING UNIT (ROLLING STOCK) COORDINATES

Since when the rolling stock enters the track circuit, the latter switches to the shunt mode of operation, it is necessary to fix this fact. The algorithm for determining the mode of operation of the track circuit consists in detecting, based on the state of the track relay, the fact that the track circuit is not working in normal mode at this time. The next step is to separate the control mode from the shunt mode. It can be implemented by comparing the value of the track circuit input impedance in the current state with its value in another mode of operation. With the same value of the track circuit insulation resistance, its input impedance is different in different operating modes. Even with a track circuit insulation resistance value of 0.5 Ohm/km, the minimum difference between its input impedance values in the control and shunt modes of operation for a 50 Hz coded track circuit with a length of 2.5 km is 0.34 Ohm. With higher values of track circuit insulation resistances, the difference between input impedance values in control and shunt modes of operation will increase. Therefore, it is possible to separate the shunt mode from the control mode by the input impedance module of the track circuit.

It should be noted that it is rather difficult to separate the shunt and normal operating modes of the track circuit using this approach since the values of the track circuit input impedance in these modes are almost the same (especially at low values of the insulation resistance). Therefore, it is necessary to separate these modes according to the state of the track relay.

When discovering the fact that the track circuit is currently operating in shunt mode (according to the results of determining the operation mode of the track circuit) to determine the coordinates of the shunt placement (the first wheel pair of the locomotive), it is necessary to perform simulation of the track circuit in the shunt mode of operation. The purpose of this simulation is to detect the dependence between the voltages and currents at the input of the track circuit (supply side) and its input impedance value on the coordinate of the shunt placement at different values of the track circuit insulation resistance.

Modeling the code track circuit with a frequency of 50 Hz in the shunt mode of operation was carried out using the classical approach according to the model shown in Fig. 2.

When determining the coordinates of a moving unit, we used to divide the voltage by current at the input of the track circuit, which is its input resistance (impedance) to reduce the number of informative parameters and simplify calculation procedures [8, 18, 21]:

$$Z_1 = \frac{U_{1S}}{I_{1S}}. \quad (13)$$

Fig. 2. The model for determining the coordinate of the shunt placement based on the track circuit input impedance.

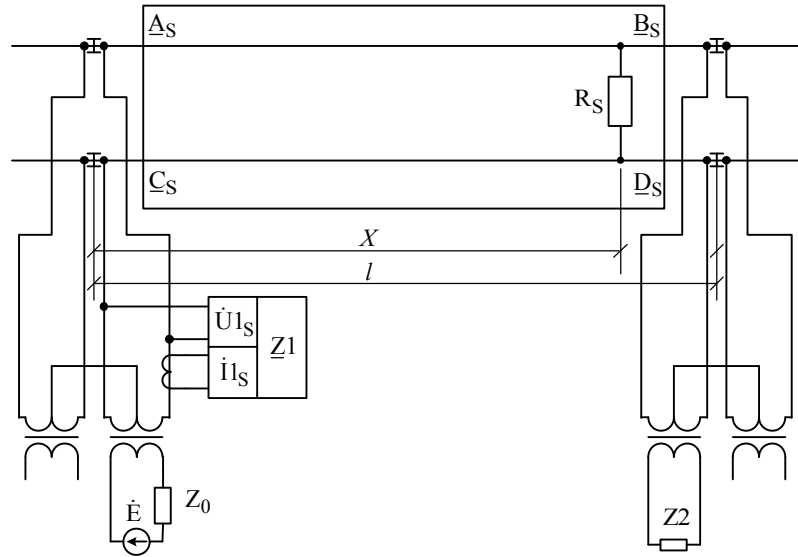

The relationship between the voltage and current at the beginning of the track circuit (supply side) and the voltage and current at its end (relay side) is expressed by (2).

From the expression (13), taking into account the equation of states (2) and the values of the coefficients, we obtain:

$$Z_1 = \frac{U_{1S}}{I_{1S}} = \frac{A_S Z_2 + B_S}{C_S Z_2 + D_S} = \frac{Z_w^2 \cdot \text{sh}(\gamma \cdot X) + Z_2 \cdot \text{ch}(\gamma \cdot X) \cdot Z_w}{Z_2 \cdot \text{sh}(\gamma \cdot X) + \text{ch}(\gamma \cdot X) \cdot Z_w}. \quad (14)$$

In the shunt mode of operation, the shunt resistance serves as the track circuit load resistance ( $Z_2 = R_S$ ). Therefore:

$$Z_1 = \frac{Z_w^2 \cdot \text{sh}(\gamma \cdot X) + R_S \cdot \text{ch}(\gamma \cdot X) \cdot Z_w}{R_S \cdot \text{sh}(\gamma \cdot X) + \text{ch}(\gamma \cdot X) \cdot Z_w}. \quad (15)$$

Using this expression, calculations were made for track circuits with a signal current of 25, 50, 420, 480, 580, 720, and 780 Hz. For example, Fig. 3 shows the calculated values of the input impedance of the code track circuit with a signal current of 50 Hz when the insulation resistance changes from 1 to 50 Ohm/Km. Grounding of contact-line supports and changes in the shunt placement coordinate in the direction from the relay side to the supply side of the track circuit with a step of 10 m were also taken into account.

From expression (15), we determine the coordinate of the moving unit (rolling stock):

$$X = \pm \frac{\ln \left( \frac{\sqrt{(Z_1 - Z_w) \cdot (Z_1 - Z_w) \cdot (Z_1 + Z_w) \cdot (Z_1 + Z_w)}}{Z_w^2 - Z_1 \cdot Z_S - Z_1 \cdot Z_w + Z_S \cdot Z_w} \right)}{\gamma}. \quad (16)$$

Or, after simplification:

$$X = \pm \frac{\ln \left( \frac{Z_1 \cdot Z_S - Z_w^2 + Z_1 \cdot Z_w - Z_S \cdot Z_w}{Z_1 \cdot Z_S - Z_w^2 - Z_1 \cdot Z_w + Z_S \cdot Z_w} \right)}{2 \cdot \gamma}. \quad (17)$$

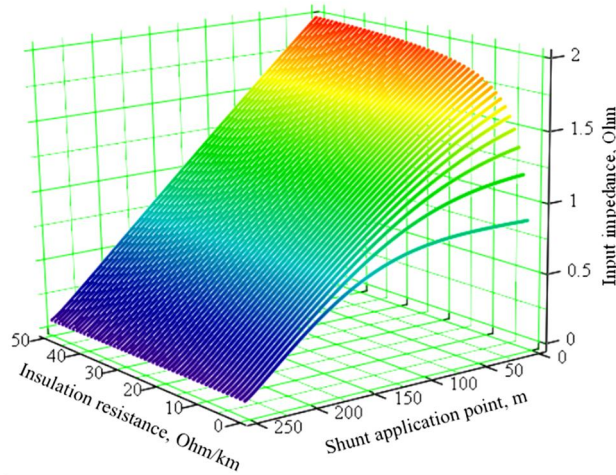

Fig. 3. Dependence of the track circuit input impedance in the shunt mode of operation on the change in insulation resistance (y-axis) and the coordinates of the shunt placement (points 1-250 – x-axis)

Since the coordinate is a positive number, then:

$$X = \frac{\ln \left( \frac{Z_1 \cdot Z_S - Z_w^2 + Z_1 \cdot Z_w - Z_S \cdot Z_w}{Z_1 \cdot Z_S - Z_w^2 - Z_1 \cdot Z_w + Z_S \cdot Z_w} \right)}{2 \cdot \gamma} \quad (18)$$

Using formula (18), it is possible to determine the coordinate of the shunt placement (of the first wheel pair) in the shunt mode of the track circuit operation.

The dependence of the input impedance of the AC code track circuit with a frequency of 50 Hz and a length of 2.5 km on the coordinate of the shunt placement at insulation resistance values of 1, 2, 5, 10 and 50 Ohm/km is shown in Fig. 4.

From Fig. 4, it can be argued that with an insulation resistance of 1 Ohm/km at placement coordinates over 1.5 km, the input impedance changes within insignificant limits. Therefore, for such long track circuits (for coordinates > 1.5 km), determining the reliable value of the shunt placement coordinate is difficult. However, for the overlaying track circuits used when approaching level crossings (< 1 km), the error may be up to 3 %. The error will also be negligible for the tuned track circuits.

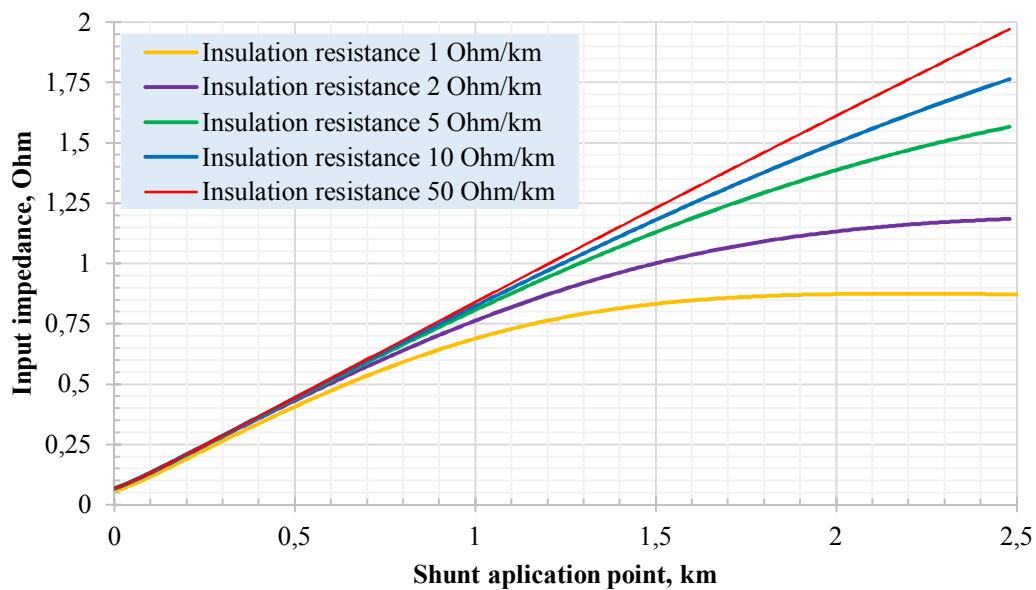

Fig. 4. Dependence of the track circuit input impedance on the shunt placement coordinate, at track circuit insulation resistances of 1, 2, 5, 10, and 50 Ohm/km.

#### 4. DETERMINATION OF TRACK CIRCUIT SECONDARY AND PRIMARY PARAMETERS

Formula (18) includes the values of the wave resistance and the propagation coefficient of the track circuit, which, in turn, depend on the resistance of the rail line insulation (on electrified sections – the equivalent resistance of the rail line insulation). Since the indicated resistance differs according to the operating conditions, it must be determined in advance. It can be done either in the shunt mode of operation for the moment when the train enters the track circuit (the train coordinate value is known, which is equal to the track circuit length) or during the period when the track circuit works in the normal mode of operation.

For any track circuits with the length  $l$  and the value of the rail's specific resistance  $z$ , the value of the track circuit input impedance in both normal and shunt modes of operation will be uniquely determined by its insulation resistance (on electrified sections – the equivalent resistance of the rail line insulation).

To determine the insulation resistance in the normal operating mode, we will use the ratios between the voltage and current at the beginning and the end of the track circuit (2).

The input resistance of the track circuit relay side is determined by the expression [3, 8, 18]:

$$Z_2 = \frac{A_2 Z_R + B_2}{C_2 Z_R + D_2}, \quad (19)$$

where  $Z_2$  – input resistance of the equipment and relay connected to the relay side of the track circuit;  $Z_R$  – track relay resistance;  $A_2, B_2, C_2, D_2$  – coefficients of the four-pole connected between the track circuit and the track relay.

The voltage and current at the beginning of the track circuit ( $U_1, I_1$ ) are determined by measurement, then we calculate the input impedance of the track circuit  $Z_1 = \frac{U_1}{I_1}$ .

In turn, the input resistance through the values of the coefficients of the track circuit four-pole is determined as  $Z_{1N} = \frac{A_N \cdot Z_2 + B_N}{C_N \cdot Z_2 + D_N}$ . Whence, taking into account the properties of the four-pole coefficients

$A_N = D_N$  and  $A_N \cdot D_N - B_N \cdot C_N = 1$ , we define them by solving the system of equations.

Next, we determine the track circuit spreading factor:

$$\gamma = \frac{\text{arcch}(A)}{l}; \quad (20)$$

and its wave resistance

$$Z_w = \frac{B}{\text{sh}(\text{arcch}(A))}. \quad (21)$$

In addition, given that the resistivity of the rails is defined as

$$z = Z_w \cdot \gamma, \quad (22)$$

the value of the spreading factor and wave resistance of the track circuit can be corrected since the resistivity is known for all rail types and does not depend on weather and other factors.

It is possible to determine the insulation resistance having determined the secondary parameters of the track circuit:

$$r_i = \frac{Z_w}{\gamma}. \quad (23)$$

Since the insulation resistance does not change radically over a short period, we can use the thus obtained track circuit secondary parameters to determine the coordinate through the track circuit input impedance in the shunt mode of operation.

In addition to the above, it is possible to organize internal logic using a powerful mathematical apparatus using computer technology. It will make it possible, by using classification algorithms, to increase the accuracy of recognition. In turn, this will ensure the insensitivity of such systems to external influences and, in general, increase both the reliability of such systems and the safety of train traffic [18].

## References

1. Theeg G. & Vlasenko S. (2020) *Railway Signalling & Interlocking. 3ed Edition*. Germany, Leverkusen: PMC Media House GmbH. (in English)
2. National Academies of Sciences, Engineering, and Medicine. (2018). *A Transit Agency Guide to Evaluating Secondary Train Detection/Protection Systems in Communications-Based Train Control Systems*. doi: 10.17226/25063 (in English)
3. Aliev, R. (2021). A Rail line model with distributed parameters of track circuit. *IOP Conference Series: Materials Science and Engineering*, 1152(1) (pp. 012018). doi: 10.1088/1757-899X/1152/1/012018 (in English)
4. Lorang, X., Kerbal, S., Lemarchand, L., Le Cam, V., & Mogoro, J. J. (2018). New detection criteria and shunting monitoring in railway track circuit receivers. In *IWSHM-RS 2018, 2nd International Workshop on Structural Health Monitoring for Railway Systems* (pp. 1–10). (in English)
5. Hellman, A. D., & Poirier, P. J. (2019). *Analysis of non-track-circuit highway-rail grade crossing train detection technologies (No. DOT/FRA/ORD-19/47)*. United States. Federal Railroad Administration. Office of Research, Development & Technology. (in English)
6. Withers, J. (2021). *Track Circuit Shunting Performance Study [Research Results] (No. RR 21-13)*. United States. Department of Transportation. Federal Railroad Administration. Office of Research, Development & Technology. (in English)
7. Zhang, B. G., Ma, W. J., & Chang, G. W. (2019). Diagnosis approach on compensation capacitor fault of jointless track circuit based on simulated annealing algorithm. In *Advances in Computer Communication and Computational Sciences: Proceedings of IC4S 2017, 1* (pp. 417–426). doi: 10.1007/978-981-13-0341-8\_38 (in English)
8. Serdiuk, T., Feliziani, M., & Serdiuk, K. (2018). About electromagnetic compatibility of track circuits with the traction supply system of railway. In *2018 International Symposium on Electromagnetic Compatibility (EMC EUROPE)* (pp. 242–247). doi: 10.1109/EMCEurope.2018.8485034 (in English)
9. Sadikov, A. N. (2021). Analysis of promising systems for monitoring the state of rail lines for the railways of the Republic of Uzbekistan. *European Scholar Journal (ESJ)*, 2(8). 81–83 (in English)
10. Honcharov, K. V. (2013). Povyshenie ustojchivosti tonalnyh relsovyh cepej v usloviyah fluktuacij soprotivleniya ballasta [Improving the stability of tonal track circuits under fluctuations of ballast resistance]. *Nauka ta prohres transportu. Visnyk Dnipropetrovskoho natsionalnoho universytetu zaliznychnoho transportu [Science and progress of transport. Bulletin of the Dnipropetrovsk National University of Railway Transport]*, 6(48), 23–31. doi: 10.15802/stp2013/19674 (in Russian)
11. Zagirnyak, M., Prus, V., Rodkin, D., Zachepa, Y., & Chenchevoi, V. (2019). A refined method for the calculation of steel losses at alternating current. *Archives of electrical engineering*, 68(2), 295–308. doi: 10.24425/aee.2019.128269 (in English)
12. Boteler, D. H. (2021). Modeling geomagnetic interference on railway signaling track circuits. *Space Weather*, 19, e2020SW002609. doi: 10.1029/2020SW002609 (in English)
13. Lucca, G. (2019). Influence of railway line characteristics in inductive interference on railway track circuits. *IET Science, Measurement & Technology*, 13(1), 9–16. doi: 10.1049/iet-smt.2018.5021 (in English)
14. Mielnik, R., Sulowicz, M., Ludwinek, K., & Jaskiewicz, M. (2018). The reliability of critical systems in railway transport based on the track rail circuit. *Analysis and Simulation of Electrical and Computer Systems*, 377–393. doi: 10.1007/978-3-319-63949-9\_25 (in English)
15. Mariscotti, A. (2020). Impact of rail impedance intrinsic variability on railway system operation, EMC and safety. *International Journal of Electrical and Computer Engineering*, 11(1), 17–26. doi: 10.11591/ijece.v11i1.pp17-26 (in English)
16. Havryliuk, V., & Nibaruta, R. (2022, September). Mathematical model of the induced AC interference in DC rails of a double-track system. In *2022 Asia-Pacific International Symposium on Electromagnetic Compatibility (APEMC)* (pp. 133–135). doi: 10.1109/APEMC53576.2022.9888737 (in English)
17. Aliev, R. M. (2021). Mathematical model of a tonal rail chain without insulating joints with current receiver in shunt mode. *Transport and Telecommunication Journal*, 22(3), 312–320. doi: 10.2478/ttj-2021-0024 (in English)
18. Havryliuk, V. I., Voznyak, O. M., & Meleshko, V. V. (2016). Improving the positioning accuracy of train on the approach section to the railway crossing. *Nauka ta prohres transportu. Visnyk Dnipropetrovskoho natsionalnoho universytetu zaliznychnoho transportu [Science and progress of transport. Bulletin of the Dnipropetrovsk National University of Railway Transport]*, 1(61), 9–18. doi: 10.15802/stp2016/60936 (in English)
19. Aliev, R. M., & Aliev, M. M. (2021). Mathematical model of the sensor for controlling the condition of the track section with an adaptive receiver at the free condition of the controlled section. In *Journal of Physics: Conference Series*, 1973(1), 012021. doi: 10.1088/1742-6596/1973/1/012021 (in English)

20. Voznyak, O. (2020). Sposib vyznachennia vtorynykh parametriv reikovoï linii [The method of determining the rail line secondary parameters] (Patent of Ukraine No 144462). Retrieved from: <https://base.uipv.org/searchINV/search.php?action=viewdetails&IdClaim=271638> (in Ukrainian)

21. Voznyak, O. M., & Havryliuk, V. I. (ed.) (2019). *Zabezpechennia bezpeky ruchu na zaliznychnykh pereizdach: Monohrafiia. [Ensuring traffic safety at railway crossings: Monograph]*. Vydavnytvo DNUZT [publishing house DNURT] (in Ukrainian).

Received 14.03.2023; Accepted in revised form 28.04.2023.

## МЕТОД ВИЗНАЧЕННЯ КООРДИНАТИ ЗАЛІЗНИЧНОЇ РУХОМОЇ ОДИНИЦІ В МЕЖАХ РЕЙКОВОГО КОЛА

**Анотація.** Метою цієї роботи є вирішення однієї з важливих проблем на залізничному транспорті – контроль за положенням рухомих одиниць в межах перегонів. Для вирішення цієї проблеми запропоновано метод постійного моніторингу рейкового кола із визначенням координати накладання поїзного шунта в шунтовому режимі роботи. Оскільки у складі моделі є первинні параметри рейкової лінії, які з часом можуть змінювати свої значення, то запропоновано їх визначати в іншому (нормальному) режимі роботи рейкового кола.

Отже, відповідно до запропонованої моделі, спочатку здійснюється визначення вторинних та первинних параметрів рейкового кола у нормальному режимі роботи рейкового кола. Далі, вже у шунтовому режимі його роботи, отримані параметри використовуються під час визначення координати рухомої одиниці.

За цим методом, насамперед, визначається режим роботи рейкового кола, який полягає у визначенні стану за його вхідним імпедансом. Виконання цього кроку здійснюється у два етапи: на першому етапі, за станом колійного реле, констатується факт, що рейкове коло не працює у нормальному режимі роботи, а на другому – за значенням вхідного імпедансу рейкової лінії відокремлюється шунтовий режим від контрольного.

У шунтовому режимі роботи рейкової лінії визначається координата, а за потреби – швидкість та прискорення рухомої одиниці, яка знаходиться у межах цього рейкового кола. Для підвищення точності визначення зазначених параметрів, у нормальному режимі роботи рейкового кола, за вимірними значеннями струму, напруги і фазового зсуву між ними, уточнюються значення вторинних параметрів рейкової лінії шляхом розв'язання оберненої задачі. Зазначений метод не потребує проведення значного об'єму обчислень та дає змогу визначити вторинні параметри рейкової лінії, а через них – і опір її ізоляції.

Використання окресленого методу дає змогу визначати відстань, а за потреби – швидкість та прискорення рухомої одиниці, яка знаходиться в межах рейкового кола. Отримані параметри можна використати для контролю за рухомими рейковими одиницями на перегонах між станціями. Застосування цього методу також може бути корисним на ділянках наближення до залізничних переїздів з метою реалізації фіксованого часу сповіщення. Крім цього, завдяки використанню окресленої моделі, можливо також, у контрольному режимі роботи визначити і координату пошкодження рейкової лінії, що дасть змогу зменшити витрати часу на виявлення та усунення пошкодження.

**Ключові слова:** рейкове коло, вхідний імпеданс, координата рухомої одиниці, параметри руху, підвищення стану безпеки