

UDK [004.7-047.72]:656.2

METHODOLOGY FOR FORMING COMPETENCES IN STUDENTS OF SPECIALTIES «COMPUTER ENGINEERING», «CYBERSECURITY AND INFORMATION PROTECTION» WHEN COMPLETING A COURSE PROJECT IN THE DISCIPLINE «COMPUTER NETWORKS»

МЕТОДИКА ФОРМУВАННЯ КОМПЕТЕНТНОСТЕЙ У ЗДОБУВАЧІВ СПЕЦІАЛЬНОСТЕЙ «КОМП'ЮТЕРНА ІНЖЕНЕРІЯ», «КІБЕРБЕЗПЕКА ТА ЗАХИСТ ІНФОРМАЦІЇ» ПРИ ВИКОНАННІ КУРСОВОГО ПРОЄКТУ З ДИСЦИПЛІНИ «КОМП'ЮТЕРНІ МЕРЕЖІ»

Rakhomova V. M. / Пахомова В. М.

s.t.s., as. prof. / к.т.н., доц.

ORCID: 0000-0002-0022-099X

Ukrainian State University of Science and Technology:

«Dnipro Institute of Infrastructure and Transport»,

Ukraine, Dnipro, Lazaryan St., 2, 49010

Український державний університет науки і технологій:

«Дніпровський інститут інфраструктури і транспорту»

Україна, Дніпро, вул. Лазаряна, 2, 49010

Abstract. The proposed methodology «NeuralRoutingNetwork» for the formation of professional and subject competencies of applicants for the degree of «bachelor» in the specialties «Computer Engineering», «Cybersecurity and Information Protection» when performing a course project in the discipline «Computer Networks»: 1) obtaining an idea of the organization of routing in modern computer networks based on the use of the created neural network tool; 2) compiling a configuration of a neural (fuzzy) network for determining routes in a computer network; 3) creating a model of a neural (fuzzy) network in accordance with the compiled structure using the selected neuropackage; 4) preparing samples for training and testing the created neural (fuzzy) network; 5) determining the optimal parameters of the created neural (fuzzy) network; 6) assessing the accuracy of determining routes in a computer network based on the created neural network tool.

Keywords: competence, course project, computer network, routing, neural network tool, configuration, optimal parameters, accuracy.

Анотація. Запропонована методика «NeuralRoutingNetwork» щодо формування фахових та предметних компетентностей здобувачів ступеня «бакалавр» спеціальностей «Комп'ютерна інженерія», «Кібербезпека та захист інформації» при виконанні курсового проєкту з дисципліни «Комп'ютерні мережі»: 1) отримання уявлення про організацію маршрутизації в сучасних комп'ютерних мережах на основі використання створеного нейромережного засобу; 2) складання конфігурації нейронної (нейронечіткої) мережі щодо визначення маршрутів в комп'ютерній мережі; 3) створення моделі нейронної (нейронечіткої) мережі відповідно до складеної структури за допомогою обраного нейропакету; 4) підготовка вибірок для навчання та тестування створеної нейронної (нейронечіткої) мережі; 5) визначення оптимальних параметрів створеної нейронної (нейронечіткої) мережі; 6) оцінювання точності визначення маршрутів в комп'ютерній мережі на основі створеного нейромережного засобу.

Ключові слова: компетентність, курсовий проєкт, комп'ютерна мережа, маршрутизація, нейромережний засіб, конфігурація, оптимальні параметри, точність.

Introduction

Problem statement. The current state of the world, associated with the spread of infectious diseases and military events that threaten the lives of applicants, has led to the use of blended learning, in particular in the discipline «Computer Networks», as well as the formation of relevant professional and subject competencies in applicants for the bachelor's degree in the specialties «Computer Engineering», «Cybersecurity and Information Protection» in such complex modern conditions, which confirms the relevance of the topic.

Analysis of recent research. Competency assessment is the subject of research by many scientists. It is important to identify, analyze and generalize the experience of EU countries, major international organizations and initiatives (UNESCO, ECDL, MICROSOFT, INTEL, etc.), as well as to compare modern Ukrainian education in international studies of the quality of education (PISA, TIMSS, PEARLS) [1]. The analysis of recent research and publications revealed the following: 1) the lack of unified information and communication technologies for teaching the discipline «Computer Networks»; 2) the need to organize routing in modern computer networks based on the use of neural network technology; 3) the existence of a wide range of neuropackages suitable for creating a neural (fuzzy) network; 4) the characteristics of generation Z, and became the basis for developing our own methodology.

The purpose of the article is to develop the «NeuralRoutingNetwork» methodology for the formation of professional and subject competencies in bachelor's degree applicants in the specialties «Computer Engineering», «Cybersecurity and Information Protection» when completing a course project in the discipline «Computer Networks».

General characteristics of the «NeuralRoutingNetwork» methodology.

The proposed «NeuralRoutingNetwork» methodology enables first-degree applicants in the specialties «Computer Engineering», «Cybersecurity and Information Protection» in the discipline «Computer Networks» to: gain an idea of the organization of routing in modern computer networks based on the use of a neural network tool; configure a neural (fuzzy) network to determine routes in a computer

network; create a neural network tool in accordance with the compiled structure using the selected neuropackage; prepare samples for training and testing the created neural (fuzzy) network; investigate the optimal parameters of the neural (fuzzy) network; evaluate the accuracy of the result obtained using the created neural network tool.

Organization of routing in computer networks.

At the present stage, for the organization of routing in computer networks, research is most often carried out using the following neural networks: Hopfield network [2]; Multi Layer Perceptron (MLP) [3, 5]; Adaptive-Neural-Based Fuzzy Inference System (ANFIS) [4], as well as using the ant method [6] and the gray wolf method [7]. It should also be noted that for the organization of routing in modern computer networks, it is possible to use various metrics: the number of routers; the distance between them; the delay on routers; the bandwidth of transmission channels; losses on transmission lines; service availability, and others.

Multilayer perceptron as the main method for solving the problem.

For example, in [5], a multilayer neural network of the configuration «21–1–X–21» is used to organize the transmission of control messages in the computer network of the information and telecommunication system (ITS) of railway transport, where 21 (first position) is the number of input neurons (delays on routers); 1 is the number of hidden layers; X is the number of hidden neurons that required additional research; 21 (last position) is the number of resulting neurons (signs of the entry of computer network channels into transmission routes). A neural network was created using the Neural Network Toolbox package of the MatLAB environment (Figure 1).

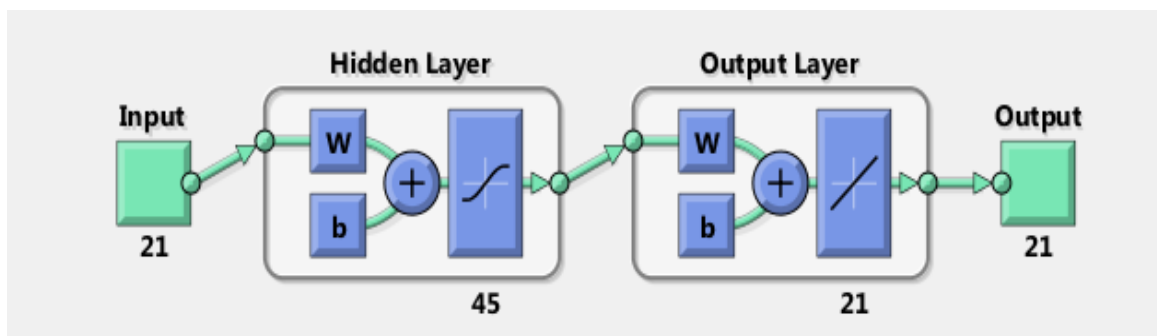

Figure 1 – Neural network of configuration «21–1–45–21» [5]

The created neural network was studied for the mean square error and the number of training epochs with different numbers of hidden neurons using different neural network training algorithms (Levenberg-Marquardt; Bayesian Regularization; Scaled Conjugate Gradient) on samples of different lengths. The result provided by the created neural network coincides with the result obtained using the Kruskal algorithm; while the correct result is achieved with a probability of 0.9.

Fuzzy network as the main method for solving the problem.

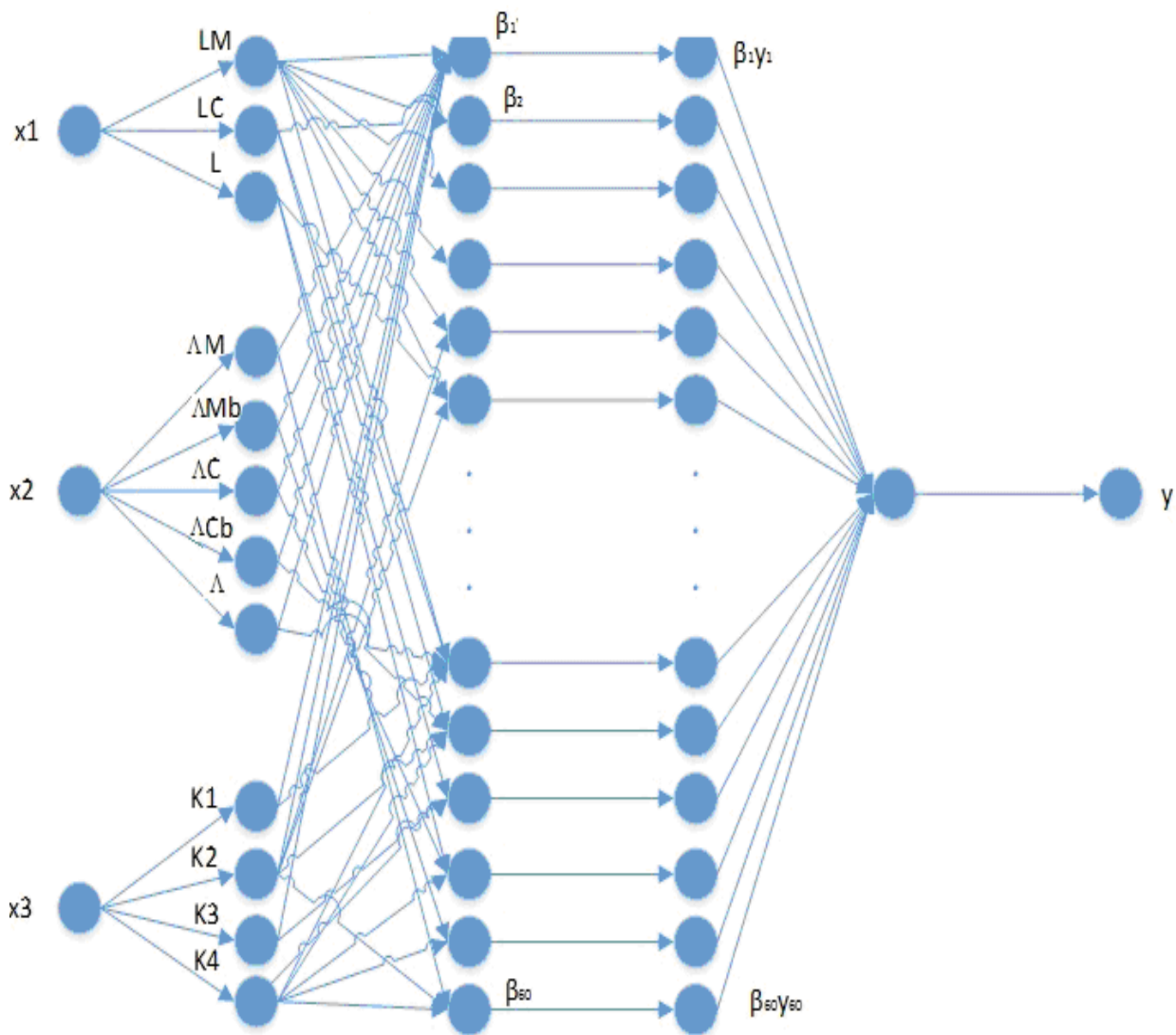

Figure 2 – Neural fuzzy network of configuration «3–12–60–60–1» [4]

For example, in [4], to determine the optimal route in a computer network, considering my fragment of the railway transport ITS, the packet residence time in routers is calculated using a fuzzy network, the input parameters of which are the following variables: x_1 – packet length (LM, LC, L); x_2 – traffic intensity (ΔM , ΔMb ,

$\Lambda C, \Lambda Cb, \Lambda$); x_3 – the number of transitions (the number of intermediate routers that make up the packet’s route) (K1, K2, K3, K4). The resulting characteristic y is the packet residence time in routers along its transmission route in the computer network (T1, T2, T3, T4). Using the Fuzzy Logic Toolbox package of the MatLAB environment, a fuzzy network of the corresponding configuration was created using the Sugeno algorithm (Figure 2).

On the created neural fuzzy network, studies were conducted on the values of the average learning error for different neuron membership functions using different learning optimization methods: Backpropa (the error backpropagation method, based on the ideas of the fastest descent method); Hybrid (a hybrid method that combines the error backpropagation method with the least squares method).

Hopfield network as the main method for solving the problem.

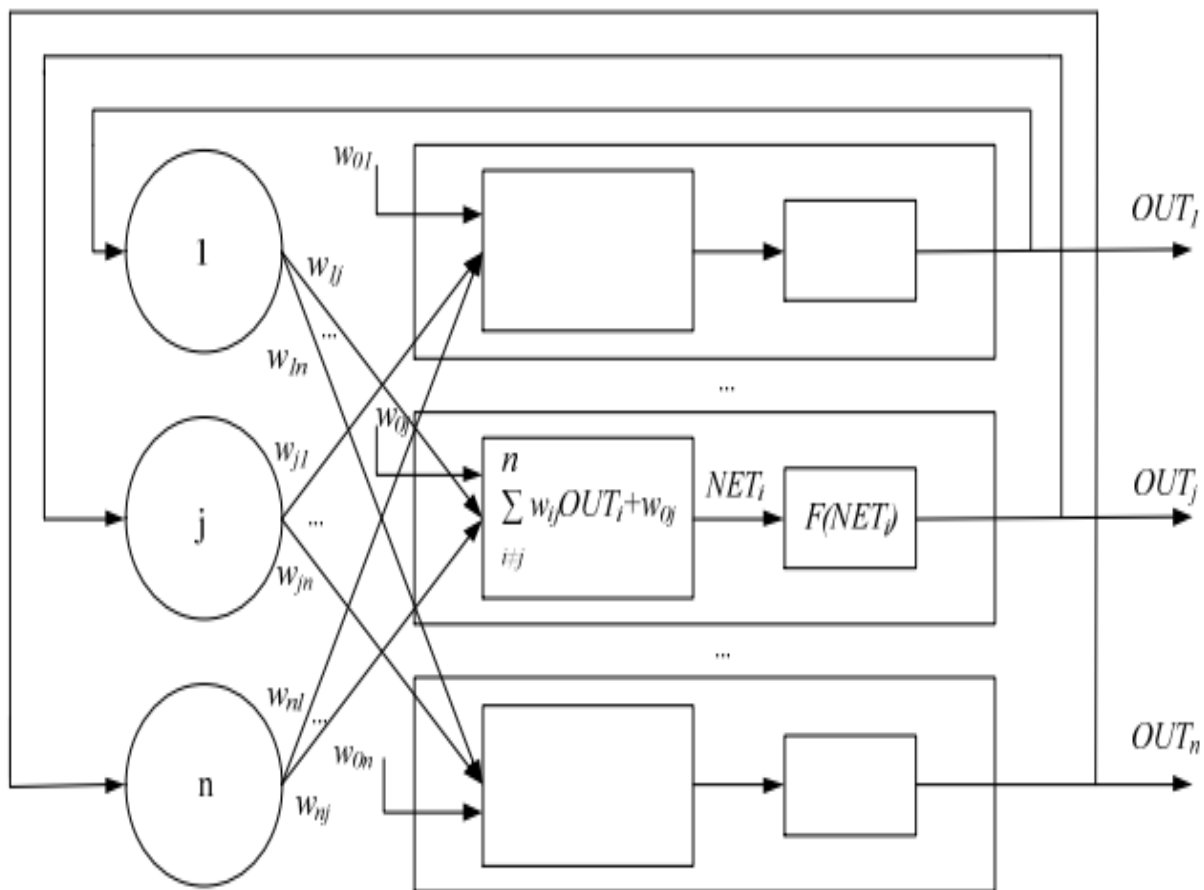

Figure 3 – Hopfield network structure [2]

For example, in the MatLAB environment, a «Hopf» software model was developed, based on a Hopfield neural network (Figure 3), to solve the traveling

salesman problem and find the shortest path on the route graph in the computer network of the Pridneprovsk Railway in Ukraine [2].

Each j -th neuron of the first layer calculates the weighted sum of its inputs – weights w_{ij} , where $i, j \in [1, n]$, as well as the bias weights w_{0j} , generating the output NET_j . Then, using the activation function, it is converted into a signal OUT_j .

Conclusions

1) The «NeuralRoutingNetwork» methodology is proposed for the formation of professional and subject competencies in bachelor's degree applicants in the specialties «Computer Engineering», «Cybersecurity and Information Protection» when performing a course project in the discipline «Computer Networks».

2) Based on the use of the «NeuralRoutingNetwork» methodology, the bachelor's degree applicant: first, masters professional competencies in the relevant specialties; second, masters subject competencies in the discipline «Computer Networks»; third, acquires practical skills in scientific activity when conducting research on the optimal parameters of the created neural (fuzzy neural) network model, which allows for more correct determination of data transmission routes in a computer network.

References

1. Bykov V.Yu., & Ovcharuk O.V. (2017) Otsinyuvannya informatsiyno-komunikatsiynoyi kompetentnosti uchniv ta pedahohiv v umovakh yevrointehratsiynykh protsesiv v osviti: posibnyk. [Assessment of information and communication competence of students and teachers in the context of European integration processes in education: a manual]. Kyiv: Pedagogical Thought, 160 p. (in Ukrainian).

2. Pakhomova V.M., & Fedorenko Y.O. (2012) Rishennia zadachi marshrutyzatsii v komp'uternii merezhi Prydniprovskoi zaliznytsi na osnovi neironnoi modeli Khopfilda. [Solution of the routing problem in the computer network of the Pridneprovskaya Railway based on the Hopfield neural model]. *Information and control systems at railway transport*, 4, 76-84 (in Ukrainian).

3. Pakhomova V.M., & Tsykalo I.D. (2018) Optimal route definition in the network based on the multilayer neural model. *Science and Transport Progress*, 6(78), 126-142. DOI: 10.15802/stp2018/154443 (in English).

4. Pakhomova V.M., & Mandybura Y.S. (2019) Optimal route definition in the railway information network using neural-fuzzy models. *Science and Transport Progress*, 5(83), 81-98. DOI: 10.15802/stp2019/184385 (in English).

5. Pakhomova V.M., Skaballanovich T.I., & Bondareva V.S. (2019) Intelligent routing in the network of information and telecommunication system of railway transport. *Science and Transport Progress*, 2(80), 77-90. DOI: 10.15802/stp2019/166092 (in English).

6. Pakhomova V.M., & Opriatnyi A.O. (2021) Prohramna model dlya vyznachennya optymal'nykh marshrutiv u kompyuterniy merezhi za dvokolonial'nym alhorytmom. [Software model for determining the optimal routes in a computer network based on the two-colonial ant algorithm]. *Science and Transport Progress*, 3(93), 38-49. DOI: 10.15802/stp2021/242046 (in Ukrainian).

7. Pakhomova V.M., & Tsykalo I.D. (2025) Vyznachennya marshrutiv peredachi v merezhi informatsiyno-telekomunikatsiynoyi systemy zaliznychnoho transportu z vykorystannyam GWO. [Determination of transmission routes in the network of the information and telecommunication system of railway transport using GWO]. *Visnyk Khersons'koho natsional'noho tekhnichnoho universytetu: vydavnychiy dim «Hel'vetyka» [Visnyk of Kherson National Technical University: Helvetica Publishing House]*, 1(92)-2. 179-184. DOI: <https://doi.org/10.35546/kntu2078-4481.2025.1.2.24> (in Ukrainian).