

**UDC 656.259.2:681.5.015.75**K. V. HONCHAROV<sup>1\*</sup>, R. V. RYBALKA<sup>2\*</sup><sup>1\*</sup>Dep. «Automatics and Telecommunications», Ukrainian State University of Science and Technologies, 2 Lazariana St, Dnipro, Ukraine, 49010, tel. +38 (056) 373 15 04, e-mail goncharovkonv@gmail.com, ORCID 0000-0002-0432-1077<sup>2\*</sup>Research Department, Ukrainian State University of Science and Technologies, 2 Lazariana St, Dnipro, Ukraine, 49010, tel. +38 (056) 373 51 09, e-mail r.v.rybalka@gmail.com, ORCID 0000-0001-7444-0517**Multi-Valued Automatic Cab Signalling System Based on the CDMA Technology**

**Purpose.** The work is aimed at the development of principles for the construction of multi-valued automatic cab signalling system (ACS) using the wide-band pseudorandom signals. **Methodology.** An analysis of existing ACS systems and modern telecommunication technologies has been performed to achieve the stated purpose. The multi-valued automatic cab signalling system CDMA-ACS has been proposed. The mentioned system utilizes wide-band pseudo-noise signals to transmit commands. System parameters: frequency band – 155...395 Hz, pseudorandom codes – 16-bit Walsh codes, spectrum spreading factor – 16, source signal bandwidth – 15 Hz, carrier modulation – DBPSK (differential binary phase-shift keying), information rate – 15 bit/sec, code combination length – 4 bits, maximum amount of commands – 256, the duration of single command transmission – 0.27 sec. Functional diagrams of generator and receiver of the multi-valued automatic cab signalling system have been designed. It has been suggested to apply the correlation method to receive the ACS signals. **Findings.** To investigate the proposed CDMA-ACS system the simulation modelling has been accomplished in MATLAB in two stages: at the first stage, the CDMA-ACS system was investigated as interference-free; at the second stage – under the influence of powerful narrow-band interferences (traction current harmonics). It has been found that the system shows high immunity to narrow-band harmonic interferences. The most significant harmonics of the traction current related to the system are 250 Hz and 300 Hz, since they are the closest to the carrier frequency of 275 Hz. It has been determined that errors in decoding the ACS commands occur if the signal-to-noise ratio becomes lower than -8 dB. To reduce the influence of 250 Hz and 300 Hz, harmonics the application of additional notch filters was proposed. **Originality.** For the first time, the authors of this work carried out research on the multi-valued automatic cab signalling system with the use of wide-band pseudo-random Walsh codes. **Practical value.** Implementation of solutions being proposed allows improving the informativeness and interference immunity for the automatic cab signalling system, reducing the duration of command transmission from the railway track to the cab.

**Keywords:** automatic cab signalling; wide-band signal; code division multiple access; Walsh codes; correlation method; interference immunity

**Introduction**

Train traffic safety largely depends on the reliable and effective operation of the locomotive automatics devices. Such devices control the train speed, inform the driver about the current train situation, train location, actual and permissible speed of the section, control the driver's vigilance, and enable automatic braking in case of safety violations [13].

In Ukraine, today, the system of continuous automatic cab signalling with numerical coding (ALSN according to transcription from Ukrainian naming) is the main locomotive means to provide train traffic safety. In such a system, the permissible train speed is determined only by considering

the current train movement situation. Herewith constant speed restrictions, which are not related to the condition, profile, curve radius or other track section peculiarities, are not considered. Temporary restrictions applied during various works at track lines are not accounted for as well. Additionally, the ALSN system does not provide the permissible speed reduction depending on the route (straight or diverging) of movement in the station and does not consider the number of the turnouts' frogs. On the line, such a system allows the driver to receive information only about the vacancy of the two block sections ahead. All this relates to the low number of values of the ALSN system, which uses only three signals: Z, Zh and KZh codes (tran-

## АВТОМАТИЗОВАНІ ТА ТЕЛЕМАТИЧНІ СИСТЕМИ НА ТРАНСПОРТІ

scripted from Ukrainian). The disadvantages of this system also include high latency (transmission delay of one command is 5...6 s), low interference immunity, outdated element base, and limited functionality.

One of the directions of further development of the ACS system is to update the locomotive equipment and apply advanced methods of signal processing. Thus, in [3] to increase the interference immunity of ALSN, it was proposed to use multi-channel adaptive filters, and in [2, 6] – the methods of digital signal processing and correlation analysis. The work [1] proposes an improved method of receiving ACS codes by «accumulation» when the receiver accumulates the signal for a certain period and then determines the received code according to the envelop pattern. There are also studies on the recognition of the ACS signals using the artificial neural networks [4, 5, 7], as well as spectral analysis and Wavelet transform [9]. However, all of these do not solve the problem of low ALSN informativeness, which is related to the low number of values of this system.

The development of multi-valued ACS involves the selection of carrier signals to transmit information to the locomotive through the rail line. Narrow-band signals are traditionally used in existing multi-valued cab signalling systems. For example, the frequency coding system ALSU (transcribed from Ukrainian naming) uses 15 commands, each of which is encoded by a combination of two unmodulated sinusoidal signals with different frequencies. The Russian ALS–YeN (transcription from Russian) system uses a carrier signal with a frequency of 175 Hz with differential binary phase-shift keying [6]. Italian BACC system, which is closest to the ALSN system, uses amplitude-modulated signals with carrier frequencies of 50 and 178 Hz and different modulation frequencies, yielding nine ACS commands [13]. Thus, traditional ACS systems use narrow-band signals, the spectrum of which is between the traction current harmonics. The ACS signal bandwidth cannot be more than 50 Hz (frequency difference of two adjacent harmonics), and considering the amplitude response of the filters is 25...30 Hz. This limits the information content and the information transfer rate over such a communication channel.

In modern telecommunication systems wide-

band signals are often used. Thus, third-generation mobile systems, systems for satellite communication and satellite navigation are based on CDMA technology, which uses wide-band pseudorandom signals [8, 10–12]. Fourth-generation mobile communications use OFDMA wide-band signals, which consist of orthogonal subcarriers [14]. Such technologies provide high interference immunity and spectral efficiency. In this regard, the research on the possibility of using the wide-band signals to transmit commands to cab signalling is relevant.

### Purpose

The purpose of this work is to develop the principles of construction of a multi-valued automatic cab signalling system using the wide-band pseudorandom signals.

### Methodology

To construct a multi-valued ACS, we propose to take a set of commands of the ALSU frequency system as a basis and expand it considering the possible increase of speed up to 250 km/h (Table 1). System commands (ACS signals) are designated by the conventional numbers, and the signal, which represents information about the higher operating speed, corresponds to the higher sequence number.

In the case of three-digit automatic block signalling on a line, three ACS signals are used: 1, 6 and 9, whereas in the four-digit automatic block signalling – four signals: 1, 4, 6 and 9. The three signals are general, and signal 4, transmitted by the yellow light signal in the case of four-digit automatic block signalling, allows movement at a speed below 50 km/h for a freight train and 80 km/h for a passenger one.

Four code signals 2, 3, 5 and 7 are used to transmit information about the predefined movement speed during the setting of the incoming route to the siding line with a divergence on the turnouts' frogs of different numbers. These signals transmit the same information about the set speed for both freight and passenger trains, considering that the value of this speed is determined not by the braking distance, but by the turnouts' frogs on the route (below 25, 50, 80 and 90 km/h, respectively, for the frogs of the 1/9, 1/11, 1/18 and 1/22 numbers). When the train moves along the main station track,

## АВТОМАТИЗОВАНІ ТА ТЕЛЕМАТИЧНІ СИСТЕМИ НА ТРАНСПОРТІ

the same ACS signals as on the running tracks are applied.

For high-speed trains, the proposed ACS system provides signals 10, 11, 12, 13, 14, which are used to transmit information about the set speed of 160, 180, 200, 220 and 250 km/h.

There are also reserve signals 15 and 16, which can be used to transmit additional information, if it is needed in the case of specific operating conditions of the line.

Table 1

Commands of multi-valued ACS

Command number	Cab signal	Controlled speed, km/h			Note
		Freight train	Passenger train	High-speed train	
block section is occupied	red	0	0	0	–
1	red yellow	0	0	0	–
2	yellow	25	25	25	diverging movement, frog 1/9
3	yellow	50	50	50	diverging movement, frog 1/11
4	yellow	50	80	80	–
5	yellow	80	80	80	diverging movement, frog 1/18
6	yellow	80	120	120	–
7	yellow	90	120	120	diverging movement, frog 1/22
8	yellow	90	140	140	–
9	green	90	140	140	–
10	green	90	160	160	–
11	green	90	160	180	–
12	green	90	160	200	–
13	green	90	160	220	–
14	green	90	160	250	–
15	reserve	–	–	–	–
16	reserve	–	–	–	–

According to CDMA (Code Division Multiple Access) technology, a wide-band pseudo-noise signal (pseudorandom sequence) is added to the information signal of each user [8, 11, 12]. Due to this, the signal spectrum is modulated and widened.

Herewith, each user occupies the entire available time-frequency resource of the communication system. Pseudorandom code combination, which is unique for each user, performs a kind of signal marking. Adding the same combination on the re-

## АВТОМАТИЗОВАНІ ТА ТЕЛЕМАТИЧНІ СИСТЕМИ НА ТРАНСПОРТІ

ceiving end allows extracting the user signal from the received group signal. Orthogonal codes are used as pseudorandom to reduce mutual inter-channel interference.

Advantages of the CDMA technology include high spectral efficiency, data confidentiality, high system flexibility, and high immunity to narrow-band interferences. The latter is related to the fact that the energy of the pseudo-noise signal is distributed over a wide frequency band, and narrow-band interference, even a very powerful one, does not significantly affect it.

In this work, the multi-valued system of automatic cab signalling (CDMA-ACS), which use pseudo-noise signals, has been proposed. Parameters of the system: frequency band – 155...395 Hz, pseudorandom codes – 16-bit Walsh codes, spectrum spreading factor – 16, information signal bandwidth – 15 Hz, carrier modulation – DBPSK (differential binary phase-shift keying), information rate – 15 bit/s, code combination length – 4 bits. Each ACS command corresponds to one of 16 unique Walsh codes and a 4-bit informational code combination. Thereby, the maximum possible

number of commands is 256 and the transmission time for one command is 0.27 s. 16 ACS commands are sufficient for practical application. Thus, the proposed parameters provide significant information redundancy, which increases the system interference immunity.

To generate CDMA-ACS signals, we offer a generator, the functional diagram of which is given in Fig. 1. Using the encoder, each ACS command is assigned a four-bit informational combination and a 16-bit Walsh code, which is added modulo two to the informational sequence. In this way, the spectrum spreading and the informational signal marking are achieved. In this case, the informational sequence of a 15 bits/s rate is converted into a wide-band signal with a chip rate of 240 symb/s, which modulates the harmonic carrier and forms a PSK signal. The DPSK, which provides high interference immunity of the communication channel, is used in the system. The obtained wide-band PSK signal is filtered, amplified and transmitted to the rail line through the protection and matching devices. Let us consider the operation of the CDMA-ACS signal receiver (see the functional diagram in Fig. 2).

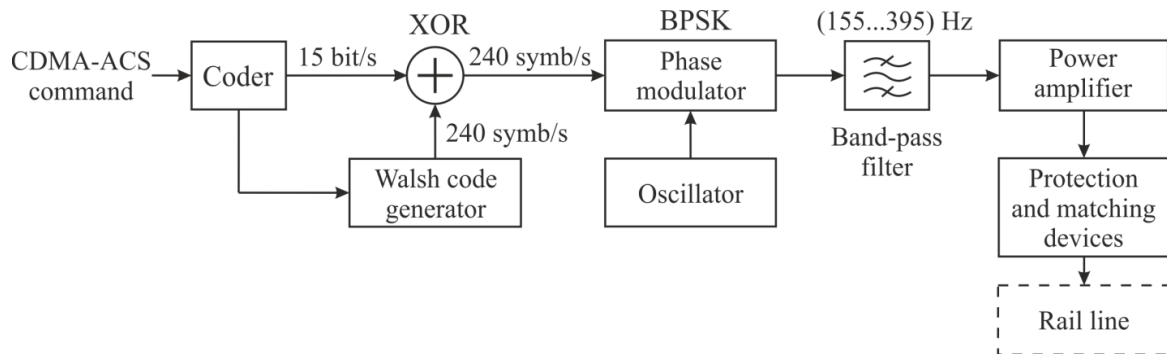

Fig. 1. Functional diagram of CDMA-ACS generator

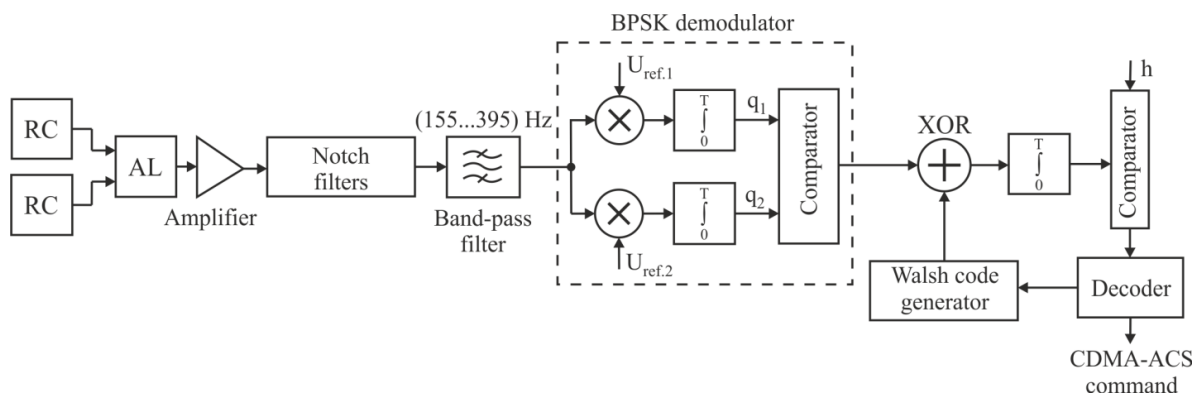

Fig. 2. Functional diagram of CDMA-ACS receiver

## АВТОМАТИЗОВАНІ ТА ТЕЛЕМАТИЧНІ СИСТЕМИ НА ТРАНСПОРТІ

The locomotive receiving coils (RC) receive the ACS signal from the rail line, and then it is transmitted to the amplitude limiter (AL), which protects the receiver from powerful interference. The signal received is amplified, filtered and applied to the phase demodulator input. To reduce the influence of traction current harmonics, the narrow-band notch filters, which tuned for the frequencies of 200, 250, 300 and 350 Hz, are used. Such filtering does not significantly affect the received ACS signal because, according to CDMA technology, the signal has a wide spectrum, i.e. useful information is not concentrated at one point, but distributed over the entire frequency band (155...395) Hz.

Phase demodulator is constructed according to the correlation principle. It determines the cross-correlation of the received signal and two reference signals with a frequency of 275 Hz and opposite phases, corresponding to logical zero and logical one. The value of each symbol is determined by comparing the obtained cross-correlations.

In the proposed system, each ACS command has two selective features: a 16-bit Walsh code and a 4-bit informational sequence. To decode the command different Walsh codes are added modulo two to the signal received after demodulation. Then the signal integration is performed for each message element. The value of each informational element (logical zero or logical one) is determined by comparing the integrator output signal and the  $h$  limit level. After this, the decoder analyses the received 4-bit combination and determines, which ACS command is transmitted over the rail line.

### Findings

To investigate the proposed CDMA-ACS system, the simulation modelling has been accomplished in MATLAB. In the first stage, the CDMA-ACS system was considered interference-free. The results are presented in Fig. 3. A 4-bit combination 1010 was chosen as the information message (Fig. 3, *a*). The duration of one element of the message is 66.7 ms, which corresponds to the information rate of 15 bits/s. A 16-bit Walsh code is added modulo two to such a signal to mark and broaden the spectrum. As a result, a pulse sequence with a chip rate of 240 symb/s is formed (Fig. 3, *b*).

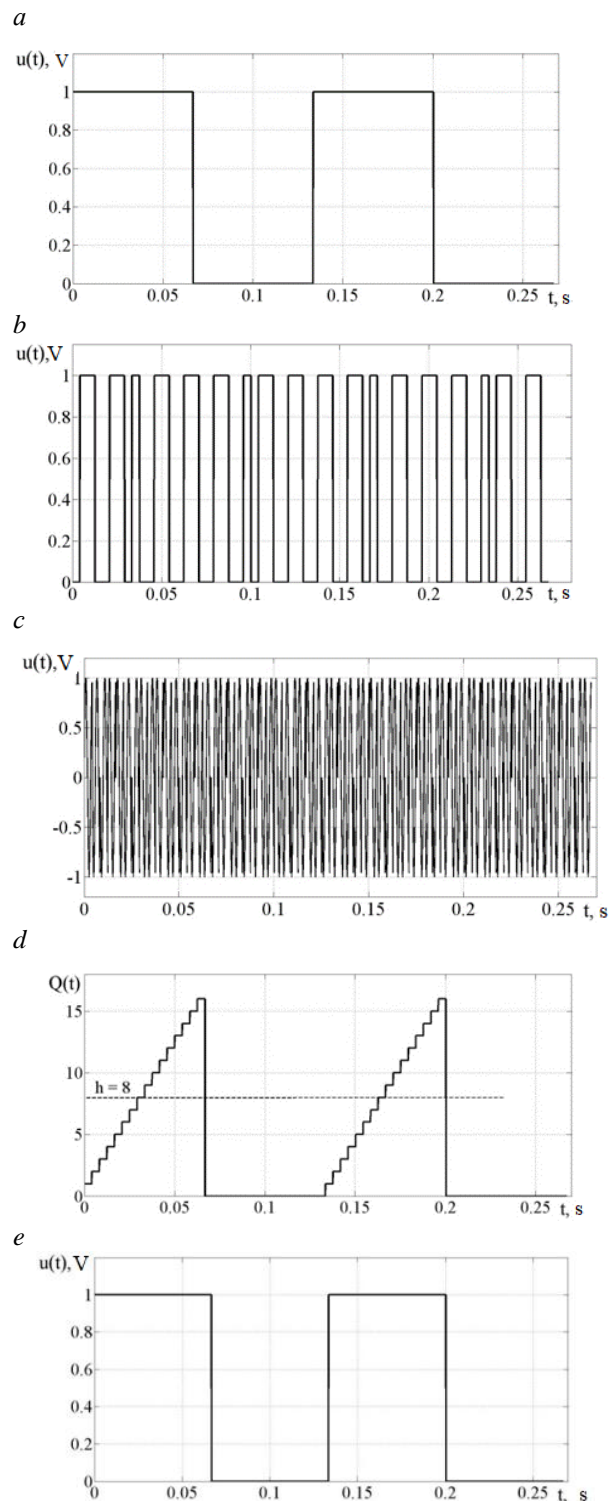

Fig. 3. Results of simulating the signal transformations in the CDMA-ACS system without interference:  
*a* – initial message; *b* – signal after spectrum broadening;  
*c* – modulated signal; *d* – signal at the output of integrator;  
*e* – received message

## АВТОМАТИЗОВАНІ ТА ТЕЛЕМАТИЧНІ СИСТЕМИ НА ТРАНСПОРТІ

After the DPSK, a harmonic signal with a carrier frequency of 275 Hz is generated, the phase of which changes according to the value of symbols transmitted. Thus, a wide-band signal is formed (Fig. 3, *c*), the spectrum of which occupies the frequency band of 155... 395 Hz. This signal, being amplified and matched, is transmitted to the rail line.

CDMA-ACS receiver amplifies, filters, demodulates and decodes the received signal. After demodulation, the reference Walsh code is added modulo two to the pulse sequence, and the result is integrated. Herewith, the integrator output signal is linearly increasing. (Fig. 3, *d*). At the end of each timing interval, this signal is compared with the  $h$  limit level, and the value of each information element is determined.

The limit level is exceeded for the first and third unit interval, whereas for the second and fourth is not (see Fig. 3, *d*). Thus, after decoding, the information sequence 1010 (Fig. 3, *e*) is obtained, which corresponds to the signal at the output of the generator.

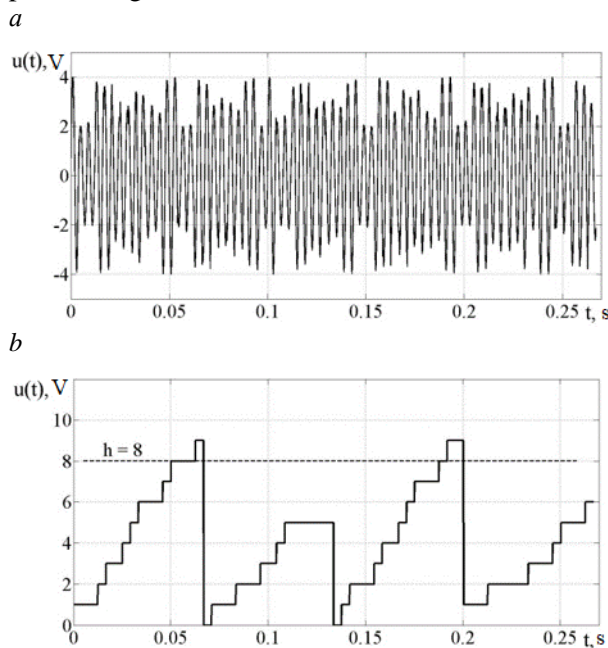

Fig. 4. Results of simulating the signal transformations in the CDMA-ACS system under the influence of interference 250 Hz:

*a* – signal at the input of receiver;  
*b* – signal at the output of integrator

At the second stage, CDMA-ACS system was simulated under the influence of powerful narrow-band interferences (traction current harmonics) excluding distortions in the rail line, filters, amplifiers and other protection and matching devices. Interferences with frequencies of 250 and 300 Hz were chosen because they are the closest to the signal carrier frequency of 275 Hz and are the most significant. In Fig. 4, *a*, CDMA-ACS signal under the harmonic interference of 250 Hz and signal-to-noise ratio of 1/3 is shown, i.e. the interference amplitude is three times higher than the signal amplitude (1 V). After its demodulation and processing at the integrator output, the signal in Fig. 4, *b* is being formed. The limit level is exceeded for the first and third unit intervals but is not for the second and fourth. Thus, after decoding, the informational sequence 1010 is obtained, i.e. the receiver decoded the signal without errors. Errors occurred with a higher interference amplitude of 250 Hz.

Fig. 5 shows the results of simulation under the influence of harmonic interference with a frequency of 300 Hz and the signal-to-noise ratio 1/2. As we can see, in this case, the information message is also decrypted without errors. Errors occurred with a further increase in the interference amplitude.

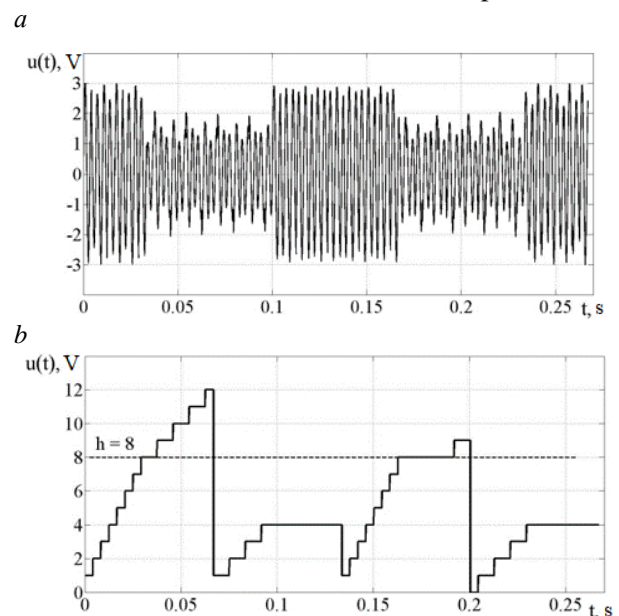

Fig. 5. Results of simulating the signal transformations in the CDMA-ACS system under the influence of interference 300 Hz:

*a* – signal at the input of receiver;  
*b* – signal at the output of integrator

## АВТОМАТИЗОВАНІ ТА ТЕЛЕМАТИЧНІ СИСТЕМИ НА ТРАНСПОРТІ

As a result of simulating the system operation, the dependency of the error ratio of CDMA-ACS command decoding on the signal-to-noise ratio with a harmonic interference of 300 Hz was obtained (Fig. 6). During the simulation, a random 4-bit message and interference of a random phase, uniformly distributed in the  $[0, 2\pi]$  interval, were formed. The 10,000 tests were performed for each signal-to-noise ratio. It was found that in the case of a signal-to-noise ratio greater than -8 dB (interference level 2.51 times higher than the signal level), decoding errors of CDMA-ACS commands do not occur. At this stage, the simulation did not consider the amplitude limiter and notch filters. In the case of applying such elements, the interference amplitude may not significantly exceed the amplitude of the useful signal.

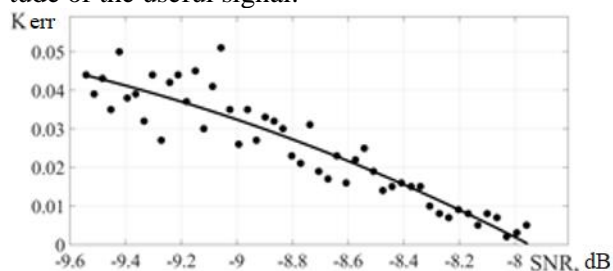

Fig. 6. Dependency of the error rate on signal-to-noise ratio: points – simulation results; line – approximation

Thus, the simulation results show a sufficiently high interference immunity of the CDMA-ACS system to narrow-band harmonic interference. This is caused by the following factors: 1) the usage of interference-immune PSK; 2) the application of the correlation method in the receiver; 3) the wide-band signal is resistant to narrow-band interference.

### Originality and practical value

The authors of this work studied a multi-valued automatic cab signalling system using wide-band pseudo-random Walsh codes for the first time.

Implementation of the proposed solutions will increase the informativeness and interference immunity of the automatic cab signalling system, reduce the command transmission time from the track to locomotive.

### Conclusions

1. The main disadvantage of the system of automatic cab signalling with numerical encoding (ALSN) is low informativeness. In Ukraine, the implementation of a high-speed rail system is virtually impossible without modernizing the locomotive safety devices by using the multi-valued automatic cab signalling.

2. This work proposes a multi-valued ACS system, which allows the transmission of at least 16 commands to the locomotive, including information on speed limits at the stations, as well as information on the current train situation on the line, taking into account the possible speed increase to 250 km/h.

3. The wide-band pseudo-noise signals were proposed to transmit ACS commands. This allowed a significant improvement in the informativeness and data transfer rate. Functional diagrams of the generator and receiver of signals of multi-valued ACS were developed, and the system parameters were proposed.

4. To study the proposed system, a simulation model in the MATLAB environment was developed. The simulation results showed high interference immunity of the system to narrow-band harmonic interference.

5. This work involves further research in the following areas: simulation of signal transformations in the CDMA-ACS system, taking into account distortions in the rail line, filters, amplifiers and other protection and matching devices; use efficiency comparison of other wide-band pseudorandom codes.

### LIST OF REFERENCE LINKS

1. Батраев В. В. Методы приема и синхронизации сигналов автоматической локомотивной сигнализации. *Автоматика на транспорте*. 2021. Т. 7, № 2. С. 175–188. DOI: <https://doi.org/10.20295/2412-9186-2021-7-2-175-188>

## АВТОМАТИЗОВАНІ ТА ТЕЛЕМАТИЧНІ СИСТЕМИ НА ТРАНСПОРТІ

2. Гончаров К. В. Синтез цифрового локомотивного приемника автоматической локомотивной сигнализации. *Наука та прогрес транспорту*. 2013. Вып. 1 (43). С. 30–38.
3. Засов В. А. Компенсация помех в приемниках сигналов автоматической локомотивной сигнализации. *Автоматика на транспорте*. 2019. Т. 5, № 1. С. 32–44.
4. Присухина И. В., Борисенко Д. В. Машинная классификация сигналов числового кода в электротехнических системах локомотивной сигнализации. *Омский научный вестник*. 2019. № 4 (166). С. 39–47. DOI: <https://doi.org/10.25206/1813-8225-2019-166-39-47>
5. Присухина И. В., Борисенко Д. В. Совершенствование алгоритмов машинной классификации состояний рельсовых электротехнических систем в составе автоматической локомотивной сигнализации. *Омский научный вестник*. 2019. № 6 (168). С. 63–69. DOI: <https://doi.org/10.25206/1813-8225-2019-168-63-69>
6. Пультяков А. В., Скоробагатов М. Э. Системный анализ устойчивости работы систем автоматической локомотивной сигнализации. *Современные технологии. Системный анализ. Моделирование*. 2018. № 1 (57). С. 79–89.
7. Сотник В. О., Бабаев М. М., Чепцов М. М. Нейромережева модель розпізнавання тривалості імпульсів та інтервалів кодів АЛСН. *Збірник наукових праць ДніЗТ*. 2013. № 36. С. 67–79.
8. Студеникин А. В., Жук А. П. Моделирование дискретных ортогональных кодовых последовательностей для систем передачи информации. *Наукоємкие технологии в космических исследованиях Земли*. 2021. Т. 13, № 1. С. 36–43.
9. Hololobova O. O., Navryliuk V. I. Application of Fourier transform and Wavelet decomposition for decoding the continuous automatic locomotive signaling code. *Science and Transport Progress*. 2017. № 1 (67). P. 7–17. DOI: <https://doi.org/10.15802/stp2017/92771>
10. Hossain A., Islam S., Ali S. Performance analysis of Barker code based on their correlation property in multi-user environment. *International Journal of Information Sciences and Techniques (IJIST)*. 2012. Vol. 2. Iss. 1. P. 27–39. DOI: <https://doi.org/10.5121/ijist.2012.2103>
11. Ilcev D. S. Analyses of Code Division Multiple Access (CDMA) Schemes for Global Mobile Satellite Communications (GMSC). *International Journal on Marine Navigation and Safety of Sea Transportation*. 2020. Vol. 14. Iss. 4. P. 805–810. DOI: <https://doi.org/10.12716/1001.14.04.03>
12. Sony D., Keerthi P., Aditya O., Sravya N. Simulation and Performance Analysis of Interleave Division Multiple Access (IDMA) in Comparison with Code Division Multiple Access (CDMA). *Asian Journal of Applied Science and Technology (AJAST)*. 2021. Vol. 5. Iss. 2. P. 90–94. DOI: <https://doi.org/10.38177/ajast.2021.5212>
13. Theeg G., Vlasenko S. *Railway Signalling and Interlocking*. International Compendium. Hamburg : Eurailpress, 2009. 448 p.
14. Wei H., Xu L., Tao J. Research on anti-jamming and anti-interception performance of MC-CDMA system based on Code-Hopping. *Journal of Physics : Conference Series*. 2021. Vol. 1920. P. 1–11. DOI: <https://doi.org/10.1088/1742-6596/1920/1/012046>

К. В. ГОНЧАРОВ<sup>1\*</sup>, Р. В. РИБАЛКА<sup>2\*</sup>

<sup>1\*</sup>Каф. «Автоматика та телекомунікації», Український державний університет науки і технологій, вул. Лазаряна, 2, Дніпро, Україна, 49010, тел. +38 (056) 373 15 04, ел. пошта [goncharovkonv@gmail.com](mailto:goncharovkonv@gmail.com), ORCID 0000-0002-0432-1077

<sup>2\*</sup>Науково-дослідна частина, Український державний університет науки і технологій, вул. Лазаряна, 2, Дніпро, Україна, 49010, тел. +38 (056) 373 51 09, ел. пошта [r.v.rybalka@gmail.com](mailto:r.v.rybalka@gmail.com), ORCID 0000-0001-7444-0517

## Багатозначна система автоматичної локомотивної сигналізації на базі технології CDMA

**Мета.** Ця робота спрямована на розробку принципів побудови багатозначної системи автоматичної локомотивної сигналізації (АЛС) із застосуванням широкопasmових псевдовипадкових сигналів. **Методика.** Для досягнення поставленої мети проведено аналіз наявних систем АЛС та сучасних телекомунікаційних технологій. Запропоновано багатозначну систему автоматичної локомотивної сигналізації CDMA–АЛС, у якій для передачі команд використано широкопasmові шумоподібні сигнали. Параметри сис-

## АВТОМАТИЗОВАНІ ТА ТЕЛЕМАТИЧНІ СИСТЕМИ НА ТРАНСПОРТІ

теми: частотна смуга – 155...395 Гц, псевдовипадкові коди – 16-бітні коди Уолша, коефіцієнт розширення спектру – 16, ширина спектру вихідного сигналу – 15 Гц, модуляція несучої – DBPSK (диференційна двопозиційна фазова маніпуляція), інформаційна швидкість – 15 біт/с, довжина кодової комбінації – 4 біти, максимальна кількість команд – 256, час передачі однієї команди – 0,27 с. Розроблено функціональні схеми генератора та приймача сигналів багатозначної автоматичної локомотивної сигналізації. Запропоновано використовувати кореляційний метод прийому сигналів АЛС. **Результати.** Для випробування запропонованої системи CDMA–АЛС проведено імітаційне моделювання в середовищі MATLAB у два етапи: на першому етапі було досліджено систему CDMA–АЛС за відсутності завад; на другому – за умови впливу потужних зосереджених за спектром завад (гармонік тягового струму). Установлено, що система має високу завадостійкість до вузькосмугових гармонічних завад. Найбільш суттєвими для системи є гармоніки тягового струму 250 та 300 Гц, оскільки вони найближчі до несучої частоти сигналу 275 Гц. Визначено, що помилки декодування команд АЛС виникають, якщо відношення сигнал / шум стає нижчим ніж –8 дБ. Для зменшення впливу гармонік 250 та 300 Гц запропоновано використовувати додаткові режекторні фільтри. **Наукова новизна.** Автори цієї роботи вперше виконали дослідження багатозначної системи автоматичної локомотивної сигналізації із застосуванням широкосмугових псевдовипадкових кодів Уолша. **Практична значимість.** Упровадження запропонованих рішень дозволить підвищити інформативність та завадостійкість системи автоматичної локомотивної сигналізації, зменшити час передавання команд із колії на локомотив.

*Ключові слова:* автоматична локомотивна сигналізація (АЛС); широкосмуговий сигнал; множинний доступ із кодовим розділенням; коди Уолша; кореляційний метод; завадостійкість

## REFERENCES

1. Batraev, V. V. (2021). Metody Methods of reception and synchronization of signals of automatic cab signalling. *Automation on Transport*, 7(2), 175-188. DOI: <https://doi.org/10.20295/2412-9186-2021-7-2-175-188> (in Russian)
2. Goncharov, K. V. (2013). Synthesis of digital locomotive receiver of automatic locomotive signaling. *Science and Transport Progress*, 1(43), 30-38. (in Russian)
3. Zasov, V. A. (2019). Compensation of noise in signal receivers automatic locomotive signaling. *Automation on transport*, 5(10), 32-44. (in Russian)
4. Prisukhina, I. V., & Borisenko, D. V. (2019). Machine classification of code signals in electric train signalling systems. *Omsk Scientific Bulletin*, 4(166), 39-47. DOI: <https://doi.org/10.25206/1813-8225-2019-166-39-47> (in Russian)
5. Prisukhina, I. V., & Borisenko, D. V. (2019). Improving the algorithms of machine classification of the state of track electrotechnical systems as a part of the system of automatic cab signalling. *Omsk Scientific Bulletin*, 6(168), 63-69. DOI: <https://doi.org/10.25206/1813-8225-2019-168-63-69> (in Russian)
6. Pul'tyakov, A. V., & Skorobogatov, M. E. (2018). The systematic analysis of the sustainability of automatic cab signalling systems. *Modern technologies. System analysis. Modeling*, 1(57), 79-89. (in Russian)
7. Sotnyk, V. O., Babaiev, M. M., & Cheptsov, M. M. (2013). Neiromerezheva model rozpiznavannia tryvalosti impulsiv ta intervaliv kodiv ALSN. *Zbirnyk naukovykh prats DonIZT*, 36, 67-79. (in Ukrainian)
8. Studenikin, A. V., & Zhuk, A. P. (2021). Modelling the discrete orthogonal code sequences for information transfer systems. *H&ES Research*, 13(1), 36-43. (in Russian)
9. Hololobova, O. O., & Havryliuk, V. I. (2017). Application of Fourier transform and Wavelet decomposition for decoding the continuous automatic locomotive signaling code. *Science and Transport Progress*, 1(67), 7-17. DOI: <https://doi.org/10.15802/stp2017/92771> (in English)
10. Hossain, A., Islam, S., & Ali, S. (2012). Performance analysis of Barker code based on their correlation property in multiuser environment. *International Journal of Information Sciences and Techniques (IJIST)*, 2(1), 27-39. DOI: <https://doi.org/10.5121/ijist.2012.2103> (in English)
11. Ilcev, D. S. (2020). Analyses of Code Division Multiple Access (CDMA) Schemes for Global Mobile Satellite Communications (GMSC). *International Journal on Marine Navigation and Safety of Sea Transportation*, 14(4), 805-810. DOI: <https://doi.org/10.12716/1001.14.04.03> (in English)

АВТОМАТИЗОВАНІ ТА ТЕЛЕМАТИЧНІ СИСТЕМИ НА ТРАНСПОРТІ

---

12. Sony, D., Keerthi, P., Aditya, O., & Stravya, N. (2021). Simulation and Performance Analysis of Interleave Division Multiple Access (IDMA) in Comparison with Code Division Multiple Access (CDMA). *Asian Journal of Applied Science and Technology (AJAST)*, 5(2), 90-94.  
DOI: <https://doi.org/10.38177/ajast.2021.5212> (in English)
13. Theeg, G., & Vlasenko, S. (2009). *Railway Signalling and Interlocking International Compendium*. Hamburg: Eurailpress. (in English)
14. Wei, H., Xu, L., & Tao, J. (2021). Research on anti-jamming and anti-interception performance of MC-CDMA system based on Code-Hopping. *Journal of Physics: Conference Series*, 1920, 1-11.  
DOI: <https://doi.org/10.1088/1742-6596/1920/1/012046> (in English)

Received: August 19, 2021

Accepted: December 17, 2021