

UDK 621.746

<https://doi.org/10.15802/tpm.1.2025.12>

Akreiev V., Cherenkov D., Prykhodko S., Melnyk S., Ovcharuk A.

## Improved heat-insulating products for ingot hot-tops in molds without extensions

**Abstract.** The fundamental principle of proper ingot solidification in metal molds - hop top part of ingot should cool and solidify slowly than the ingot body. To achieve this, typically hop top parts of ingots are insulated with special thermal insulation products. They are mounted either directly on the inner surface of the mold or installed in special hop top extensions of the mold. This approach effectively directs shrinkage defects away from the usable ingot section into hop top cut zone.

For different steel grades (alloys), depending of the application, ingot design, and casting method, hop top cut ranges from 8% to 16% of the total ingot mass.

This article presents experience in using an advanced thermal insulation insert design, which enables higher part of usable ingot metal, prevents subhead cracks in the ingot, simplify and lighten the lining of ingot hop top.

**Keywords:** thermal insulation insert, ingot, mold, hop top, hop top cut, usable part of ingot metal.

**Introduction.** Steel casting is final and one of the most responsible operations in the steel ingot production process. As a rule, the quality of steel ingot products is subject of highest requirements, which entails the need to develop and implement effective technologies, that help to reduce physical, chemical and structural heterogeneity in solidifying ingots, reduce hop top cut, and increase usable part of ingot metal.

Moreover, it should be noted that steelmaking is a costly process, both in terms of financial, energy and resource components and in terms of personnel labor. In case of defective production, all these expenses may be wasted. Even minor deviations in the casting process technology lead to a reduction of usable part of ingot, due to an in the amount of low-quality products amount, losses from defective ingots and other excessive production waste.

Unstable or unsatisfactory quality of steel ingots is most often associated with the transition of steel and alloys from a liquid to a solid state. This transformation is accompanied by numerous simultaneous physical and chemical processes. At this time during ingot formation, it is possible to set the conditions for the further defects background, that cannot be eliminated in the future by plastic deformation of the metal. A large number of simultaneously interacting factors makes it difficult to manage effectively of ingot forming processes and, as a result, to produce high-quality products that will meet the highest requirements of customers.

After casting into the mold, the steel transfers its heat to the mold walls and the environment through the upper end surface of the ingot. Solidification of ingot begins around the walls of the mold. The thickness of the ingot part that has crystallized continuously increases, and a transition zone is formed between the liquid core of the ingot and the solid part of metal. Crystals and liquid metal coexist in this transition zone in the interdendritic space. The crystallization of the ingot ends near its longitudinal axis with the formation of columnar crystals. The steel solidifies in the tree-shaped

form of dendritic crystals, whose size and shape depend on the solidification conditions and the chemical composition of the melt.

Conditions for directional solidification of the metal are created to eliminate shrinkage defects in ingots. This is achieved by increasing the cross-sectional area of the working cavity of the mold with height and by insulating ingot hot top.

The correct choice of design and dimensions of heat-insulating products for the ingot hot top is crucial for the most complete removal of the shrinkage cavity. This article will present design improvement of the heat-insulating insert, which allows to increase the usable part of ingot metal, reduce the percentage of hop top cut from the total mass of the ingot, reduce metal waste, and eliminate possible defects in the ingot.

**Defects and Flaws in Steel Ingots.** Defects and flaws that can be found on ingots and metal billets (blooms, slabs) are divided into groups:

1. Natural (or unavoidable) defects that occur during the cooling and crystallization of liquid steel in a casting mold (crystallizer, mould), as well as during the cooling of an ingot that has already been formed. These include shrinkage cavity, porosity, shrinkage porosity, gas bubble and non-metallic inclusions. It is impossible to completely eliminate natural defects in the ingot, but it is possible to influence the development of natural flaws, limiting them and thereby improving the quality of ingots, steel billets and rolled products [1].

2. Technological defects. They are formed as a result of imperfections or violations of the established operating conditions of steelmaking and casting. Such defects include transverse and longitudinal cracks, pours, belts, metallic and some non-metallic inclusions, subcortical and internal bubbles in steel ingots. Selection of the most rational designs of replaceable equipment (like molds, pallets, and hot tops) and compliance with metal casting technology ensure a sharp reduction of steel ingots technological defects [1].

© Akreiev V., postgraduate student, Cherenkov D., Prykhodko S. postgraduate student, Melnyk S., postgraduate student; Ovcharuk A. Doctor of Technical Sciences, Professor, Ukrainian State University of Science and Technologies

From the point of view of defects location in the body of ingot, defects are divided into surface and internal. Surface defects are easy to detect and in most cases can be eliminated on cooled ingots and billets by cleaning. Internal defects are detected in ingots by micro- and macro- examinations.

A separate category includes rejected ingots. Ingot rejects are mostly caused by the presence of cracks, which are divided into internal and external cracks. External cracks are divided into longitudinal and transverse cracks according to the direction of ingot axis. Hot cracks are cracks that formed on the ingot in the hot state and, accordingly, cold cracks are those that formed in the cold state of the ingot [2].

All kinds of cracks are formed during the crystallization and cooling of ingot, as well as when it is heated before rolling or during rolling (internal cracks). These stresses can be different in strength and sign depending on the shape, geometric dimensions, weight, and mode of forming, cooling, or heating of the ingot. Internal cracks called intergranular ("spider") cracks are often observed in alloy steel ingots. They are located along the ingot axis and cause delamination in the fracture. When steel that is not sufficiently refined from hydrogen is cooled, internal cracks called flocs appear [3].

Transverse cracks (Fig. 1) occur at an early stage of ingot crystallization, when the ingot does not receive free longitudinal shrinkage during solidification. Transverse cracks can form anywhere along the height of the ingot. In the upper hot top part of the ingot (Fig. 1, 1) they occur when the metal overflows and in cases where the pours were not removed before the formation of a hard crust or if the lining (patching) of the insulation was poorly performed. In the hot top part of the ingot (Fig. 1, 2) the cause of cracks is the ingot suspension due to the uneven surface of the mold or metal leakage into the gap between the mold and the hot top extension. If expanded upwards ingots are welded to the bottom or walls of the mold and there is no free longitudinal shrinkage, transverse cracks appear in the body (Fig. 1, 3) [1, 3].

The surface layers of the ingot, which cool down much faster than the inner layers, experience greater shrinkage than the inner layers. At the same time, the inner layers prevent the free contraction of the surface layers and it inevitably develop stresses, which in some places can exceed the tensile strength of the metal and lead to the formation of longitudinal cracks in any area along the height of the ingot. Such cracks are most common in ingots of circular cross-section, i.e. when the cross-section of the ingot has the smallest perimeter.

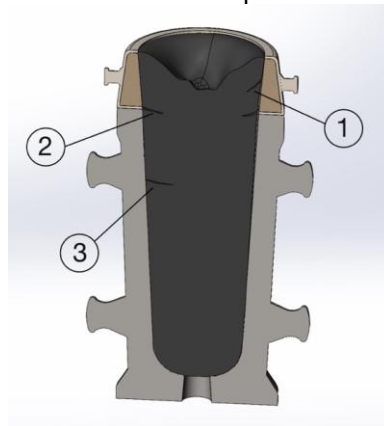

**Fig. 1. Transverse cracks in a steel ingot (1 – hot top crack, 2 – “sub” hot top crack, 3 - ingot body crack)**

Longitudinal cracks in ingots are formed as a result of a mismatch between the temperature of the poured steel and the speed of ingot mold filling. When the molds are filled with superheated metal at a high speed, a crust of insufficient thickness and strength is formed before the ingot leaves the mold walls, which ruptures when it cannot withstand the pressure of the liquid steel column. Pouring overheated metal at high speed leads to an increase of thermal stress during the ingot cooling process. Numerous studies and factory practice confirm that the formation of longitudinal cracks depends on the poured steel temperature and filling rate of ingot molds. Thus, ingots cast by the casting refractories method, which is characterized by low mold filling rates, always have fewer longitudinal and transverse cracks. It is possible to reduce the number of cracks on the ingots by reducing the pouring rate of overheated steel [4].

When steel is poured from above as a result of metal jet hitting the bottom of the ingot mold, and when it is poured by siphon-casting as a result of metal flowing out of the mold bottom during the initial period of its entry into the mold, metal splashes onto the inner surface of the ingot mold, which causes the formation of films on the bottom of the ingot. A large number of splashes and droplets lead to formation of a continuous solidified crust on the bottom of the ingot. A continuous crust of the same origin, which extends almost to the entire height of the ingot, is called a "shirt". The formation of continuous pours is only possible when steel is poured from above in a loose jet, when metal splashes continuously hit the walls of the ingot mold [3, 4].

Fig. 2 shows technological defects on ingots (from left to right): films from a sharp lifting of the stopper; films from metal jet splashing; "shirt" as a result of

casting the ingot without braking the jet until the end of pouring; line on the ingot and twists of the crust from a long break during pouring; films in the lower part of the

ingot from a rupture of the crust during pouring of hot metal.

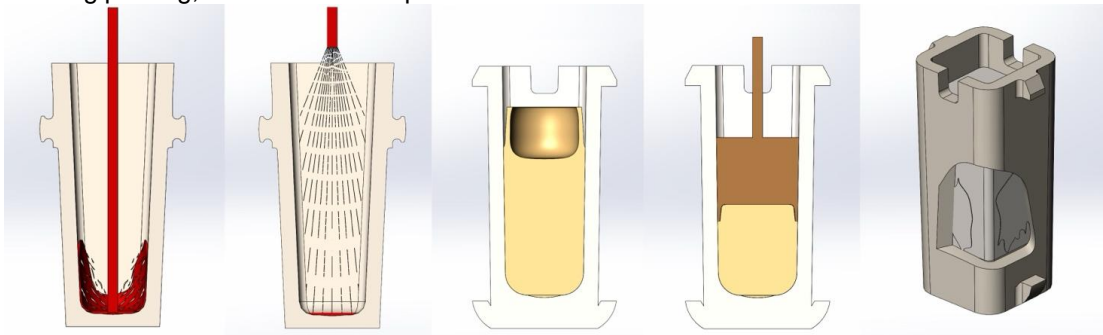

**Fig. 2. Technological defects on ingots**

Fig. 3 shows ingots with surface rejects (from left to right): a bump on ingot caused by incorrect metal jet centering; overflow of a steel ingot; grooves on an ingot caused by a large crack in the casting ingot mold.

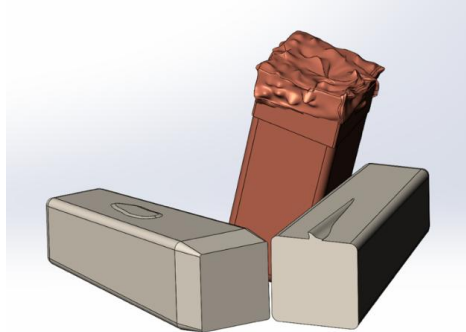

**Fig. 3. Ingot surface flaw rejects**

Sulphur, nitrogen, phosphorus, hydrogen and oxygen are in a soluble state in liquid steel and released as solid non-metallic inclusions or as separate gas phases during ingot solidification. Non-metallic inclusions affect the properties of the metal and are often the cause of rejects in ingots and billets. Non-metallic inclusions are natural (endogenous) and extraneous (exogenous) [2]:

1. Endogenous non-metallic inclusions are formed as a result of oxidation and deoxidation reactions of the metal bath, changes in equilibrium constants, decreasing in the solubility of components with decreasing temperature, and as a result of segregation processes [5, 6].

2. Exogenous inclusions enter the metal from the outside in the form of pieces of refractories, slag particles, etc. Such inclusions amount depends on the condition of the runners, ladles, siphon casting products, hot top margin and the cleanliness of the casting molds. The most effective way to reduce the amount of non-metallic inclusions in steel is to use high-quality refractories and precise adherence to technology [7].

Non-metallic inclusions are found in ingots, billets and finished products as compounds of various metals contained in steel with sulphur (sulphide), carbon (carbide), nitrogen (nitride) and oxygen (oxide). If non-metallic inclusions are located on the surface of the ingot, they are called surface inclusions or edge inclusions; if they are located at some depth in the body of the ingot, they are called internal inclusions. Non-metallic inclusions visible at low magnification, for example, through a magnifying glass, are called macroscopic; inclusions

visible only at high magnification (50 times or more) are called microscopic [6].

The form of non-metallic inclusions is mainly determined by their melting point. Non-metallic inclusions with a melting point higher than the melting point of liquid steel solidify in the steel as crystals with sharp edges; these include carbides, nitrides, oxides, and sulfides. Iron oxide, iron and manganese silicates, which have melting point below the solidification point of ingot, usually appear as balls shape, spheres (globules).

Iron sulphides and oxysulphides, having a melting point lower than the melting point of steel, are located along the grain boundaries of the steel and cause a very serious defect – hot shortness. Reducing the sulphur and oxygen content in the finished steel eliminates hot shortness, and adding elements such as manganese, titanium, vanadium, aluminium, zirconium and others that have a higher affinity for sulphur and oxygen than iron to the bath at the end of the melting process helps to produce high quality steel. Non-metallic inclusions in the ingots processing by pressure are drawn in the direction of rolling into lines or strips, resulting in a fibrous structure of metal. Transverse samples of such metal have lower strength than longitudinal samples.

The strength properties of steel products often become worse when ingots contain metal inclusions. All metal inclusions are exogenous. These are either pieces of undissolved decking that have been removed from the nozzle cup and fallen into the mold, or crusts

of frozen metal formed in siphon-casting refractories, or plugs and large films [7, 8].

**Metal Shrinkage, Shrinkage Cavity.** When metal is cooled from a temperature of 1600°C to temperature 600°C, it changes from a liquid to a solid state, with a volume reduction of approximately 4-6%. When liquid steel is cooled, its chemical and physical properties change and the ingot structure is formed. As the temperature of steel decreases, the solubility of many chemical elements and gases decreases, and they are released to a greater extent during crystallisation. The density of steel is temperature-dependent and decreases with temperature reduction in the liquid and solid states. As a result of its crystallization decrease in the volume of the metal leads to the formation of shrinkage cavities or pores in metal ingots, which can lead to a decrease of usable part of metal ingot.

Due to the change in ingot volume, the geometric volume of the mold will not be completely filled with metal. A cavity is formed, which is called a shrinkage cavity. This shrinkage cavity is concentrated in the thermal center of the ingot, where the very last portions

of the metal solidify. In addition to the shrinkage cavity, small macro voids of shrinkage origin can form in the ingot, which are most often located along the axis (central porosity) [3].

The shape and location of the shrinkage cavity in the ingot, as well as character of central porosity and dispersed shrinkage, depend on the design of the mold and heat dissipation conditions through the mold walls. To reduce the hot top cut, the top of the ingot is often made in the shape of a truncated pyramid. In this case, the lowest heat removal from the ingot head is achieved by reducing the specific cooling surface due to the conical design of the ingot top. Additionally, the hot top part is insulated with refractory materials and insulating plates using corner elements for rectangular moulds (Fig. 4). Under these conditions, the heat centre is located in the hot top part of the ingot, which ensures that liquid metal flows down the ingot throughout the solidification period. The liquid metal fills all the shrinkage cavities, and the ingot body is formed quite densely.



Fig. 4. Rectangular mold lined with heat-insulating boards using corner elements

Maintaining the metal in the hot top of the ingot in a liquid state is achieved by retaining the internal heat of the metal itself. If this is not enough to produce a high-quality ingot, the hot top is additionally heated. Gas burners, various types of electric heating, heat-insulating mixtures for insulating the metal surface, exothermic masses, exothermic heat-insulating plates and shells are used for this purpose.

The volume and location of the shrinkage cavity largely depends on the casting technology. As the metal temperature increases, the shrinkage cavity increases accordingly and it penetrates deeper into the ingot body. In order to reduce the length of the shrinkage cavity, hot metal is poured slowly whenever possible. All of the above measures should be carried out in an integrated manner to minimize shrinkage cavity or to weld it out during deformation. This will help to increase the usable part of metal ingot [9].

**Designs of the Ingot Hot Top and Their Disadvantages.** This article examines a method for manufacturing a thermal insulation insert that can be used in ingot casting molds with an upwardly expanded or constant cross-section of working cavity. It is suitable for molds with a round or polygonal cross-sectional shape.

The basic principle of ingots casting in metal molds is that the hot top part should crystallize last. For this purpose, the hot top parts of the molds are equipped with thermal insulation in the form of thermal insulation inserts located on the inner surfaces of the mold end or on the inner surfaces of the hot top extensions to prevent unwanted heat exchange with the environment.

For different steel grades (alloys), depending on the purpose, ingot design and casting method (top or siphon casting), the hot top cut is generally ranges between 8 and 16% of the total ingot weight (Fig. 5). Let us consider the methods of implementation of the ingot hot top section:

Thermal insulation products for molds lining without hot tops, which partially extend beyond the mold cavity and allow partial formation of the hot top outside the mold cavity. The disadvantage of these kind thermal insulating products is highly skilled personnel need in order to perform the lining and increased risk of metal leakage from the hot top area.



Fig. 5. Hop top cut 11% of 6,5 ton ingot 1.4541 (AISI321)

2. Thermal insulation inserts used in molds with hot top extensions lined with such inserts. The use of the hot top mold extensions with these inserts, depending on the design, has several disadvantages, including:

- high cost of the hot top metal body extensions;
- increased risk of ingot cracking;
- high labor intensity for lining;
- large hop top cut of the ingot.

3. Thermal insulation inserts used in molds without hot top extensions, where the upper part is also lined with thermal insulation materials (products). The disadvantages of using such molds include:

- need for highly skilled personnel for lining works with these kind of thermal insulation inserts;
- impossibility to use the entire volume of the mold to produce a usable part of metal ingot;
- necessity to place the hot top part of ingot in the body of the mold.

4. Thermal insulation inserts, used for producing steel ingots, installed as separate elements on the inner surface of the hot top in the mold, which has an upwardly expanded body with an internal working cavity. The hot top, mounted on the mold, consists of an outer metal body and a dense refractory lining inside. The refractory material is replaceable. The disadvantages of this type of design include:

- low usable part of ingot metal;
- increased maintenance time;
- high labor intensity.

This type of hot top is reusable, but with repeated use, the thermal insulation insert experiences significant wear and requires intermediate repairs. After several repairs, the refractory lining surface becomes distorted, making it impossible to maintain consistent dimensions of the ingot's hot top section. Additionally, the hot top has a significant weight, making installation on the mold impossible without lifting equipment.

**Problem Statement.** With a purpose of ingot casting efficiency improving, it is necessary to modify the thermal insulation insert design to achieve the following objectives:

- increase the usable part of metal ingot;
- reduce the percentage of hot top cut acc. to the total weight of the ingot, thereby minimizing metal losses;

- obtain stable dimensions of the ingot hot top section;

- simplify the lining process of the hot top in molds using thermal insulation products, reducing the risk of liquid metal leakage from the hot top;
- extend the hot top section beyond the mold cavity;
- decrease the labor intensity of the hot top manufacturing and installing;
- reduce maintenance time and overall process costs.

The task is solved by installing a heat-insulating insert on the mold body instead of the add-on to form the ingot hot top part with various options for its installation.

The proposed thermal insulation insert for the ingot hot top forming has a vertical shape with upper and lower end faces, with inner working wall and an outer wall. It is designed as a continuous structure along the perimeter. The horizontal section is shaped as an outer shoulder, corresponding to the contour of the mold's top end. The outer surface of the vertical section matches the shape of the inner surface of the upper part of the mold, ensuring a precise fit and effective thermal insulation.

The thermal insulation insert is designed as a continuous structure along the perimeter, with the thickness of its horizontal section ranging from 10 mm to 100 mm, and the thickness of its vertical section ranging from 10 mm to 50 mm. The horizontal part of the thermal insulation insert can be made flush with the top of the vertical section or positioned at the midpoint of the vertical section.

Depending on the cross-sectional shape of the mold, the cross-section of the thermal insulation insert can be circular, rectangular, or polygonal. The vertical part of the mold thermal insulation insert may have different shapes - conical, cylindrical, or polyhedral [10].

**Universal Thermal Insulation Product for Molds without Add-ons.** The thermal insulation insert consists of a vertical part (1) and a horizontal part (2), with an inner working wall and an outer wall, both having upper and lower end faces. The horizontal part (2) is designed in the shape of external shoulders, matching the contour of the mold's end face. The vertical part has a shape that matches the upper part of the mold (Fig. 6, Fig. 7).

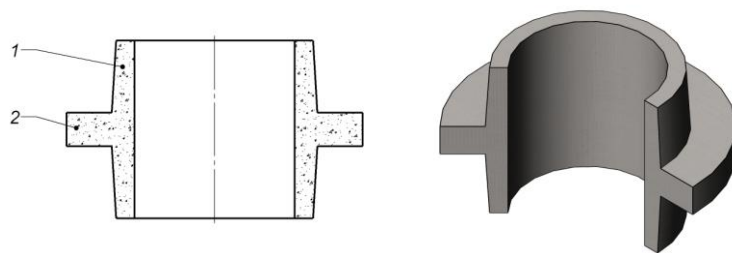

**Fig. 6. Example of thermal insulation insert design for a mold with a circular cross-section**

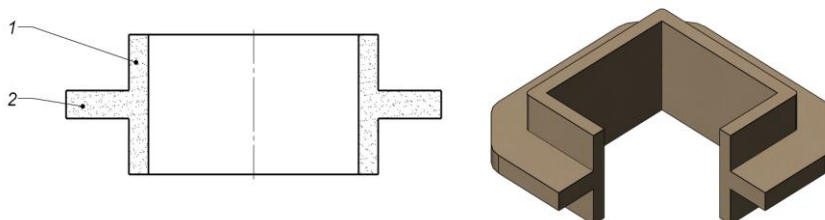

**Fig. 7. Example of the thermal insulation insert design for a mold with a square cross-section**

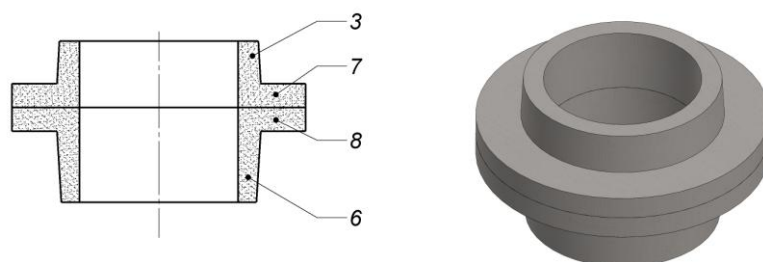

**Fig. 8. An example of the proposed design of a composite thermal insulation insert**

The horizontal part of the thermal insulation insert is designed to closely match or be equal to the dimensions and shape of the upper end face of the mold, onto or into which it is installed. The thickness of the horizontal part can range from 10 mm to 100 mm.

The vertical part of the thermal insulation insert is either conical or cylindrical, and its shape and size depend on the required volume of the hot top section and the taper of the mold cavity. The thickness of the vertical part can range from 10 mm to 50 mm.

The thermal insulation insert can be made as a single piece or composed of two elements — the lower and upper parts (Fig. 8). The insert consists of the following parts: 3 – vertical part of the upper element, 7 – horizontal part of the upper element, 8 – horizontal part of the lower element, 6 – vertical part of the lower element. The dimensions and shape of the horizontal part of the thermal insulation insert must match or closely resemble the size of the mold upper end face in order to maximize the contact area with it. The lower and upper surfaces of the horizontal part, shaped as an external shoulder of the thermal insulation insert, are designed to be flat and even.

The overall height of the thermal insulation insert (lower and upper elements), its volume, and the shape

of its internal cavity are determined based on the mass and shape of the ingot, ensuring the correct removal of the shrinkage volume into the hot top section.

The thermal insulation insert is installed into the mold cavity to a depth of 150 mm and additionally forms a hot top volume of 50 mm outside the mold cavity. For operational convenience, the thermal insulation insert is pressed against the mold body using a weighting element (7) (Fig. 9).

The shape of the thermal insulation inserts and the ratio of the horizontal and vertical (conical) parts of the product allow them to be used both for partially forming ingot hot top section inside the mold and entirely outside the mold.

The paired use of the proposed thermal insulation inserts enables the formation of the hot top section of the ingot within the mold, with the possibility of increasing the hot top section outside the mold to the required dimensions [10].

An example of the proposed thermal insulation insert design for a mold with a circular cross-section is shown in Fig. 10, where the insulation insert is pressed against the mold body (8) using a weighting element (7).

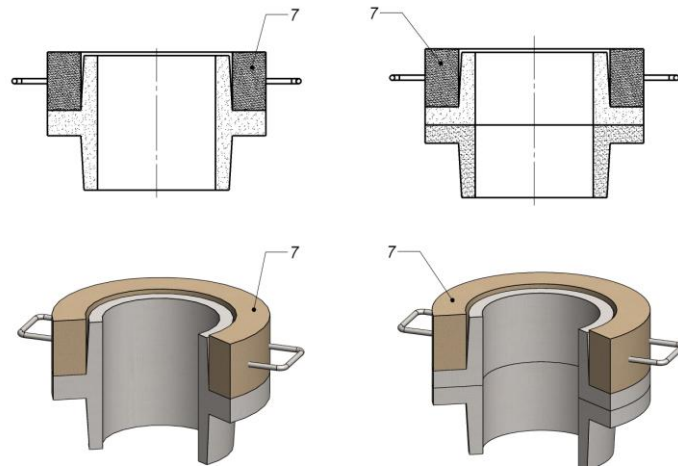

Fig. 9. Example of the weighting device installation method for a solid and assembled thermal insulation insert for a circular cross-section mold

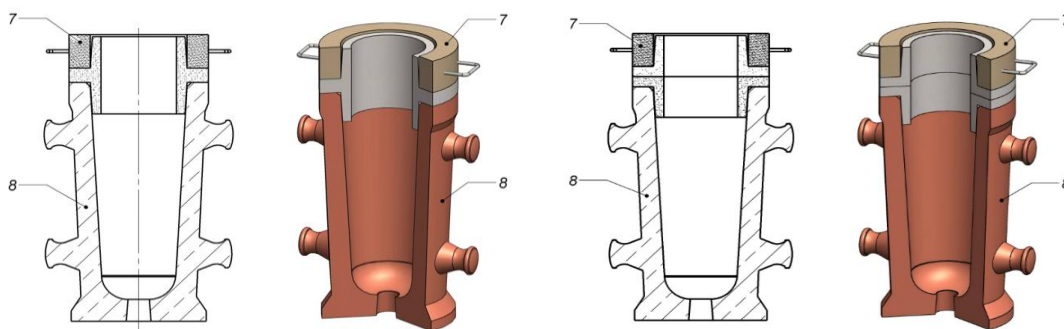

Fig. 10. Installation examples of a solid and assembled insert with a weighting element in a circular cross-section mold

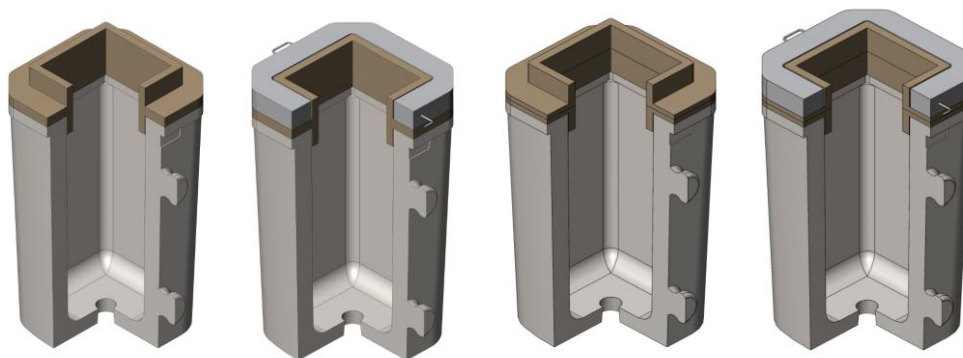

Fig. 11. Installation examples of a solid and assembled insert with a weighting element in a square cross-section mold

Fig. 11 illustrates the same concept for a mold with a square cross-section. Similar thermal insulation inserts designs are used for rectangular and polygonal molds.

The outer surface of the lower vertical part of the thermal insulation insert follows the geometry of the inner cavity of the upper part of the mold and fits tightly against its surface. Meanwhile, the outer surface of the vertical part of the upper thermal insulation insert can have a variable shape, but must provide the required wall thickness. This design of the thermal insulation insert can be used for installation on molds with a direct taper (where the cross-sectional area of the working

cavity increases upward) and a flat upper end face (without projections and slots).

The outer surface of the vertical part follows the geometry of the inner cavity of the upper part of the mold and fits tightly against its surface. The dimensions of the lower and upper vertical parts of the insert (or the vertical parts of the lower and upper components when used in pairs) are selected to extend a significant portion of the hot top section beyond the upper end face of the mold, thereby increasing the ingot body mass.

To prevent the thermal insulation insert from lifting due to the pressure of molten metal and to ensure a tight fit of the insert against the mold surface, as well

as proper contact between the surfaces of the upper and lower components when used in pairs, a ring-shaped or custom-shaped weighting element of the required mass is placed on its horizontal section. Molten metal penetration from the mold is prevented by the tight adhesion of the insert to the mold surface, both within the working cavity and along the upper end face. This is achieved through the precision of geometric dimensions, the pressing of the weighting element from above and the extensive total contact area between the insert and the mold.

When using paired inserts, molten metal penetration between the lower and upper parts is prevented by the tight fit of their horizontal surfaces, which is ensured by dimensional accuracy and compression from the weighting element above [10].

The weighting element can be made of either metal or reinforced concrete. During the casting process, the weighting element is not subject of mechanical stress and does not come into contact with the liquid metal.

When the proposed products replace heat-insulating products that are completely submerged in the working volume of the casting mold, the weight of the ingot increases due to an increase in the size of ingot usable part (with a constant weight of the hot top part), which results in:

- a) reduction of specific costs for the formation of hot top cut;
- b) reduction of specific costs related to mold operation and maintenance.

Replacing hot top extensions lined with reusable refractory materials by proposed insulating inserts allows

to reduce the weight of the ingot hot top part. This is ensured by high thermal insulation properties of the product and the absence of a cooling effect on the liquid metal of the extension body.

The fit of the lower vertical part of the insulating product to the wall of the inner surface of the casting mold, combined with the pressing of horizontal part of the insert (product) against its end, minimizes to an insignificant level ingot hanging on the upper end of the mold and for this reason prevents the formation of surface cracks on the ingot.

The installation of the insulating insert and the weighting element on top of the mold is significantly simpler, faster, and more reliable than assembling refractory lining elements inside the mold cavity or hot top extension body. This enables the use less qualified personnel for mold preparation before metal casting.

The average ingot mass when filling the mold with the thermal insulation insert, following the installation scheme shown in Fig. 12, is 0,78 tn. The mass of the solidified hot top head is 67 kgs, which, when converted into percentage terms, accounts for 8,6% compared to 12% with the existing hot top extension. Due to the high thermal insulation properties of the material and the geometric dimensions of the thermal insulation insert, it may even allow for the complete elimination of the ingot's hot top cut in some forging applications [10]. According to the table, the use of a thermal insulation insert increases the usable part of ingot metal by 3% (i.e., by 30 kg per ton). This results in significant cost savings, when casting ingots from high-cost metal.



Fig. 12. Round-section mold (0,78 tn) with composite thermal insulation insert

Table 1. Example of ingot production and usable part of ingot metal

Ingot production technology	Ingot weight, t	Weight of usable metal, t	Yield of usable metal, %
With known hot top extension	1,0	0,88	88
With improved thermal insulation insert	0,78	0,71	91

The yield of usable metal when casting an ingot with a known hot top extension is 0,88 tons (when casting 1 ton into a mold), while in the case of the developed heat-insulating insert, the yield of usable metal is

0,71 tons (when casting 0,78 tons into a mold). When converted to 1 ton of metal by using the heat-insulating insert, the savings of usable metal is 34 kg per ton in favor of the developed heat-insulating insert.

Additionally, when switching to the developed heat-insulating product, there is no need to modify the equipment and change the existing production technology [10].

### Conclusions

The proposed heat-insulating insert without extension allows combining the advantages of the lined heat-insulating inserts technology and the technology of mold casting cavity lining with heat-insulating products, while ensuring high technical and economical

performance of the ingot, its quality, and simplicity of preparatory operations. The use of improved thermal insulation insert makes it possible to:

- increase the yield of usable metal to 91% of the total ingot weight;
- reduce the hot top cut by 25% of the base value;
- reduce metal waste;
- obtain stable dimensions of the ingot hot top part;
- reduce maintenance time;
- reduce labor intensity.

### References

1. Zaveryukha N. V., Volkov L. A., Chechetkin A. V. (1974) Steel Casting, Metallurgy [in Russian].
2. Yefimov V. A. (1976) Casting and Crystallization of Steel, Metallurgy [in Russian].
3. Dubrov N. F., Vlasov N. N., Korrol V. V. (1975) Steel Casting, Metallurgy [in Russian].
4. Steel Casting Processes and Ingot Quality: Collection of Scientific Papers (1989) Academy of Sciences of the Ukrainian SSR, Institute of Casting Problems, Kyiv [in Russian].
5. Shulte Yu. A. (1964) Non-Metallic Inclusions in EAF Steel, Metallurgy [in Russian].
6. Non-Metallic Inclusions and Gases in Foundry Alloys: Proceedings of the 10th International Scientific and Technical Conference, May 12-16, 2003. Zaporizhzhia: ZNTU [in Ukrainian].
7. Levin B. A., Salnikov A. S., Knokhin V. G. (2004) Collection of Technological Instructions for Steelmaking in an Open Arc Furnace, PJSC "Dniprospeksstal", Zaporizhzhia [in Russian].
8. John Campbell. (2011) Complete Casting Handbook. Metal Casting Processes, Metallurgy, Techniques and Design. Butterworth-Heinemann; 1st edition, ISBN-13: 978-1856178099.
9. Levada A. G., Makarov D. N., Hyakinen V. I., Khvastunov V. D. (2008) Experience in Using Insulating Materials for Steel Casting by Siphon Casting Method. *Science, Technology, Production*, 6: 78-81 [in Ukrainian].
10. Pat. 157426 Ukraine, MPK B22D7/00, B22D7/10. Teploizoliatsiina vstavka dlia formuvannia prybutkovoї chastyny zlytka/Akreiev V.V., Akreiev A.V., Cherenkov D.V.; № u202400330; zaiavl. 19.01.2024; opubl. 16.10.2024, Biul. № 42/2024.

Надійшла до редакції / Received by the editorial board: 10.01.2025

Прийнята до друку / Accepted for publication: 10.03.2024