

Stability issues of the continuous welded rail track on the concrete sleepers on the curves with radius $R \leq 300$ m

Prof. Victor Vasylevich Rybkin, Doctor of Technical Sciences - V. Lazaryan Dnipropetrovsk National University of Railway Transport, Dnipropetrovsk, Ukraine
E-mail: rybkin@ipo.diit.edu.ua

Associate Professor Nicolai Petrovich Nastechik, Candidate of Technical Sciences - V. Lazaryan Dnipropetrovsk National University of Railway Transport, Dnipropetrovsk, Ukraine

Postgraduate Ruslan Volodymyrovych Marcul - V. Lazaryan Dnipropetrovsk National University of Railway Transport, Dnipropetrovsk, Ukraine
E-mail: guaranga_mr@mail.ru

Correspondence to: Prof. Victor Vasylevich Rybkin, Doctor of Technical Sciences - V. Lazaryan Dnipropetrovsk National University of Railway Transport, 2 Lazaryana Str., Dnipropetrovsk, Ukraine, 49010

ABSTRACT

This paper describes the economic and technological benefits of installing continuous welded rail (CWR) track on sharp (radius ≤ 300 m) railway curves. A new form of prestressed concrete sleepers developed by the V. Lazaryan Dnipropetrovsk National University of Railway Transport is shown to improve the lateral shift resistance of CWR track in sharp curves and the use of anchor sleepers on tangents is shown to make it possible to lower the fastening temperature of the CWR track in order to increase the rail lifespan.

Keywords: continuous welded rail (CWR) track; track configuration; stability; sharp curves; anchor sleepers

1 Introduction

In the past few decades the use of prestressed concrete sleepers in railway tracks has become more widely adopted due to the shortage of wooden sleepers, their high cost, and their short lifespan caused by the need for frequent spikings on curves. Spiking reduces the lifespan of wooden sleepers to only 8 years on curves having a radius $R \leq 300$ m;- this is only one-fifth of the lifespan of concrete sleepers. On such curves, heavy rolling stock causes large-scale residual deformations that lead to track configuration faults in the layout. These faults can also weaken the shift resistance of the rail and sleeper grid in the lateral horizontal plane. This paper proposes a solution to these problems that utilizes the laying of temperature-stressed, continuous welded rail (CWR) track into small-radius curves.

This is of topical interest in connection with increasing train speeds, heavier axial loads, and increasing railway traffic volume which in turn lead to the need for increased track strength and deformation resistance.

Use of the CKД65-Б type of fastening construction (Figure 1) makes it possible to use concrete sleepers on curves with any radius without changing the configuration of the III1-1 type of sleepers. To test this configuration, a 19-m section of track which had curves with radiuses ranging from 200 m to 450 m was removed and reconfigured. This fastening method enabled the configuration of the track width on the curved sections accurate to 1mm. Within this span the track gradually widened from 0 mm to 14 mm and narrowed from 28 mm to 0 mm.

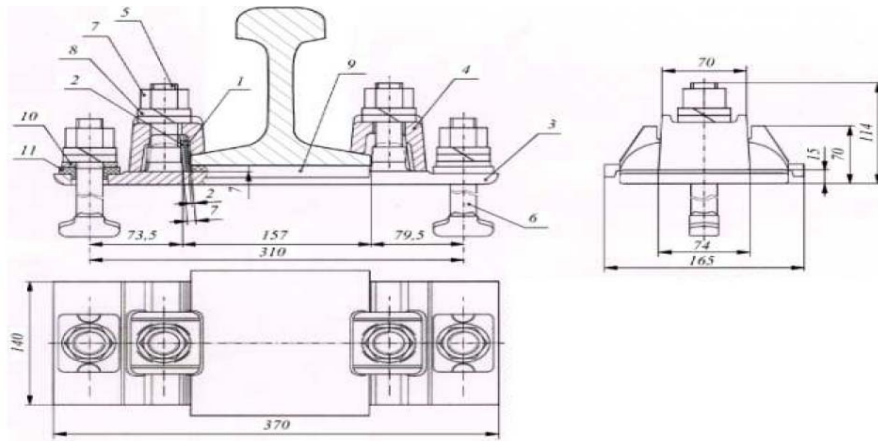

Figure 1 The CKД65-Б type of fastening.

- 1: Adjusting card, 2 mm wide (two items);
 2: Adjusting card, 3 mm wide (one item); 3: Plate КБЛ 65; 4: Terminal ПКЛ;
 5: Clip bolt; 6: Insert bolt; 7: Screw nut; 8: Double coil washer; 9: Plate ПРБ-4;
 10: Plain washer ШП-1.1; 11: Insulating sleeve.

The use of CWR on curves with a radius $R \leq 300$ m has proven to be efficient but not necessarily reliable from the point of view of its stability in cases where standard construction elements are utilized. This means that with a given $R \leq 300$ m curvature, the present method of CWR track construction does not meet all the necessary stability parameters. This is because the standard concrete sleepers of the ШП-1 type do not have sufficient resistance to shift across the track, which results in ejection of the CWR track in summer.

2 Economic benefits of CWR track on curves with radius $R \leq 300$ m

We made preliminary theoretical calculations to determine the efficiency of the implementation of CWR track with CKД65-Б fastening on curves with radius $R \leq 300$ m (Nastechik *et al.*, 2013).

Our specific goal was to make a techno-economic comparison of two variants of the permanent way on track curves: jointed track on wooden sleepers versus CWR on concrete sleepers. To this end, we analyzed several research works of prominent scientists and railway engineers who have dealt with the methodology of techno-economic calculations related to track facilities (Lubimov, 1967; Shahunants, 1967; Shahunants, 1972; Shahunants, 1987; Yakovleva, 1999; Danilenko, 2010). Our conclusion is that the most widely approved and comprehensive methods are those that fully analyze the economic efficiency of the permanent way during the whole service life of the track, and these are based on a total costs analysis approach (Danilenko, 2010):

(1)

K_i

where K_i is the capital investment of laying the i -variant of the track construction, in roubles/km (the capital costs of track repair); C_i is the annual operating cost of the i -variant, in roubles/km/ year;

C_{overhead} is the overhead costs (on full health-improving, average and other kinds of repair);

t_i is the year during which the costs are incurred;

t_{kp} is the service life of the most long-term variant of the track construction, in years;

η_t is the coefficient of the removal cost which was determined by the formula:

$$\eta_t = \frac{1}{(1 + E_{\text{HH}})^t} \quad (2)$$

where E_{HH} is the standard for the reduction of the non-overhead costs (standard efficiency coefficient).

These calculations assume that the curved section of the track has a radius of ≤ 300 m. They were done for a track 1 km long containing curves and tangents. Within that kilometer of track containing the curves was changed within 50 to 1000 m in the calculations. We determined the correlations between the rates of the lateral wear of the railhead for CWR and jointed track on sharp curves, assuming:

- the wear rates are similar; and
- the wear rate of the rails of CWR track on concrete sleepers is 1.5 times less than on the wooden sleepers, following (Yakovleva, 1999).

It is generally known that on curves with a radius ≤ 300 m the lateral wear of the rails is the factor that determines rail replacement. Our calculations for the different track categories were based on the official Ukrainian statute relating to the planned preventive maintenance track work on the Ukrainian railways, («The statute about the performance of the planning-preventive repairing track work on the Ukrainian railways», 2004. Approved by the Ukrzaliznytsia Decree of 10 August 2004, No. 630-ІІЗ, Kyiv, p 40) and analyzed range of traffic volume from 10 to 50 mln. ton-km/h. The calculation results of the payback periods of CWR track on curves having a radius of 200 m and 300 m with a curvature length of 400 m per 1 km of track are illustrated in Figures 2 and 3.

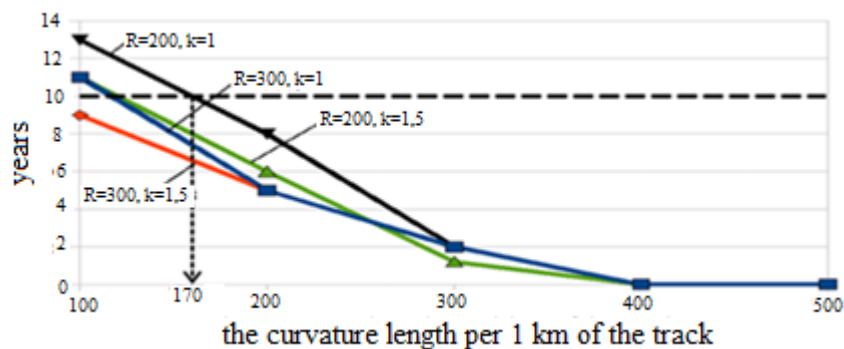

Figure 2 The payback periods of CWR track with curves of $R = 200$ m and $R = 300$ m (traffic volume - 10 mln. ton-km/h)

K - the coefficient of the ratio of the lateral wear of the jointed track value on wooden sleepers to the value of the CWR wear on concrete sleepers.

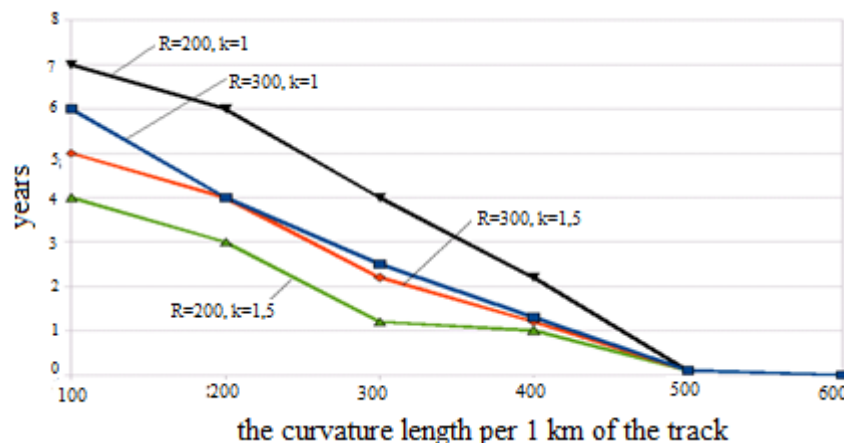

Fig. 3. The payback periods of CWR track with curves of $R = 200$ m and $R = 300$ m

(traffic volume - 50 mln. ton-km/h).

K = the coefficient of the ratio of the lateral wear of the jointed track value on wooden sleepers to the value of the CWR wear on concrete sleepers.

As shown, in Figures 2 and 3, under the conditions described above, the laying of this CWR track configuration in the given curves, instead of jointed track on wooden sleepers, is economically efficient. Similar payback results under other traffic volumes were obtained.

3 Theoretical research on the problem CWR track stability in the lateral horizontal plane

Theoretical research done by the V. Lazaryan Dnipropetrovsk National University of Railway Transport found that the CWR track configuration on curves with a radius ≤ 300 m should have a lateral shift resistance force 1.8 times greater than that of track with standard III1-1 type sleepers. CWR track stability on curves with a radius < 200 m equals the CWR track stability on curves with a radius - 400 m.

We conducted a broad review of the scientific works in other countries on this topic. Russia's National Research Institute of Railway Transport has developed a new concrete sleeper configuration of the III3-ДУ type, which has increased resistance against ballast shift (Krysanov, 2009) and is shown in Figure 4.

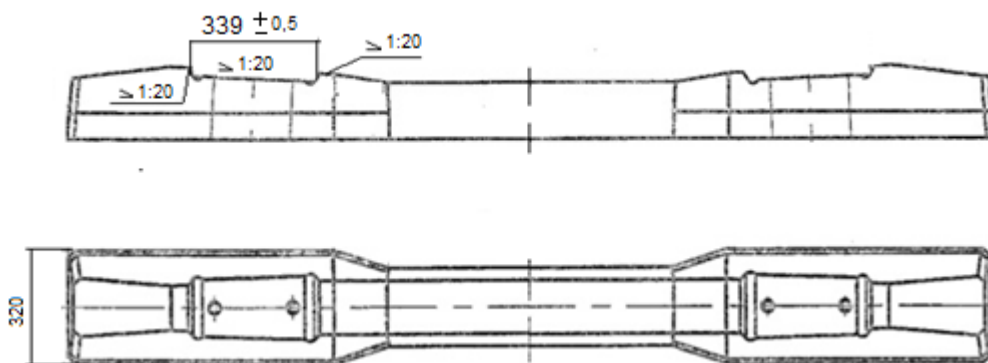

Figure 4. Prestressed concrete sleeper of the III3-ДУ type

Klimenko (2006) concluded that the shift resistance of the III3-ДУ sleeper was, on average, 1.5 to 1.9 times greater than the shift resistance of the standard III1-1 sleeper. However, a new, expensive technology is needed to manufacture this type of sleepers.

In Europe (Italy, Germany, and Austria) a track configuration with concrete framed sleepers has been developed (Ermakov, 2009), which is shown in Figure 5. However, there are some drawbacks related to the technology of manufacturing these new framed sleepers, and secondary deformations still occur during operation, especially, on curves with minor radiuses.



Figure 5 A track on concrete framed sleepers on the Turin Line (Italy)

Germany has developed duo-block sleepers of polymer concrete (Ermakov, 2009) and sleepers of the BSS type, which have a doubled sleeper width of 57 cm. This sleeper configuration is illustrated in Figure 6. The increased mass of this configuration has

not produced a particularly beneficial effect during operation, and its price, has grown considerably.

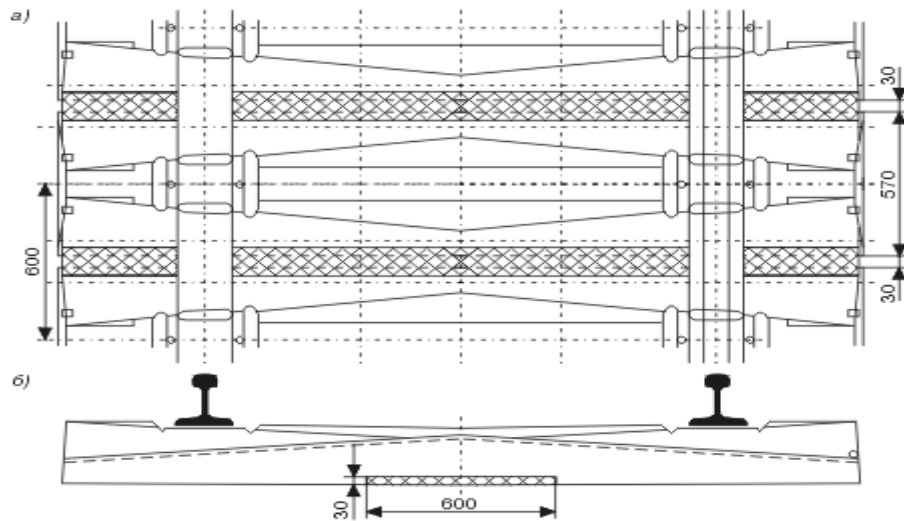

Figure 6 The BBS type of sleeper. (a) View from above; (b) side view.
The view from above (a). The side view (b).

These new configurations have one common drawback: the change in manufacturing technology is a very expensive process. Also, the technical equipment for railway track repair and maintenance of sleepers of this type does not yet exist.

4 Development of a concrete sleeper configuration with increased resistance to shift in the horizontal plane

The V. Lazaryan Dnipropetrovsk National University of Railway Transport has researched the development of a new type of III1-1 sleeper with increased shift resistance. This approach meets the requirements of simple configuration form, ease of manufacturability when assembling the rail and sleeper grid on the unit-assembling facilities of the track mechanical station, the fact that laying the rail and sleeper grid into the track can be done with currently available machinery, and the appropriate maintenance regimes can be implemented with current technology and equipment.

Accordingly, a new configuration of a III1-1 A type of anchor sleeper has been developed. This sleeper differs from the standard III1-1 sleeper by the presence of pivots that project from the sleeper foot on 100 mm down. The configuration of this new sleeper is shown in the Figure 7.

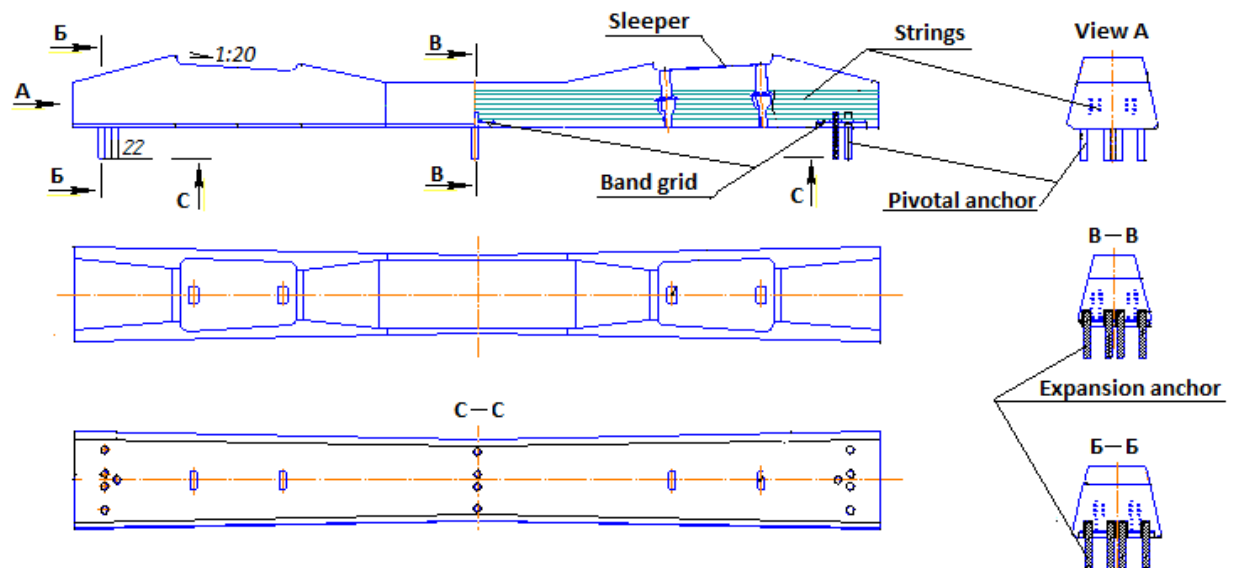

Figure 7. Configuration of the new III1-1 A type of anchor sleeper

The main advantage of the new III1-1 A type of anchor sleeper over the other types described above is its simple configuration form. To manufacture it there is no need to design new forms or change the production technology.

5 Lateral shift resistance forces of the new III1-1 A sleeper

The V. Lazaryan Dnipropetrovsk National University of Railway Transport conducted laboratory researches to validate the new the III1-1 A sleeper design. Results indicate that the shift resistance of unanchored III1-1 A sleepers is 500 kilogram-force (5 kH), whereas the shift resistance of sleepers with tenoned anchors arranged into three sections along the full length of the sleeper is 1500 kilogram-force (15 kH), which is three times greater than that of the unanchored III1-1 A sleepers.

Thus because anchored III1-1 A sleepers have shift resistance greater than 1.5 ton-force, they can be used on curves with a radius $R \leq 300$ m. This method also improves the ejection stability of CWR track in the transverse direction to the center-line of the track.

6 Utilizing anchored III1-1 A sleepers on curves and tangents

The V. Lazaryan Dnipropetrovsk National University of Railway Transport currently suggests using anchored sleepers on tangents. This will make it possible to lower the fastening temperature of CWR track lengths. If the fastening temperature is lowered by 10 °C, the tension stress in the lengths will be reduced to only 25 MPa (that is, by 7 %). This is expected to increase the rail lifespan by 1.32 times. If the fastening temperature is lowered by 15 °C, the rail lifespan will be increased by 1.5 times. In that case, the repair/replacement interval would be increased to 1.2 billion tons of train load.

7 Conclusions

Under certain conditions, utilizing CWR track configurations with concrete sleepers on minor radius curves is more economically efficient than jointed track on wooden sleepers. Also, improved concrete sleepers can increase the lateral shift resistance in sharp curves, and using anchored sleepers on tangents makes it possible to lower the fastening temperature of the CWR track in order to lower the rail tension stress and increase the rail lifespan.

REFERENCES

- Danilenko E.I, 2010. Arrangement, designing and calculations, interaction with the rolling stock. In: The Railway Track. Vol. 2, ed. - Inpress Publishing House, Kyiv.
- Ermakov V.M, Bekish A. A, 2009. Modern configurations of the concrete sleepers and intermediate fastenings for the CWR track: Tutorial. Peterburg State University of Means of Communication, St. Petersburg.
- Klimenko V.Y. The resistance increase of concrete sleepers, - Bulletin No. 1, 2006, www.zdmira.com.
- Krysanov L.G, 2009 Sleepers with increased shift resistance. In: Track and Track Facilities, National Research Institute of Railway Transport, Moscow No. 3, pp. 24-25.
- Lubimov E.A, 1967. The determination of the possible lifespan of the wooden sleepers. The collected scientific articles of Kharkiv Institute of Transport Engineers, Kharkiv No. 90, pp. 65-70.
- Nastechik M.P, Rybkin V.V, Markul R.V, Arbutov M.A, Kalenik K.L, 2013. The economic efficiency of CWR track laying on curves with minor radius. The collected scientific articles of Donetsk Institute of Railway Transport, Donetsk Issue 32 pp. 218-225
- Shahunants G.M, 1967. The work of the track and its maintenance costs. The collected scientific articles of Moscow Institute of Transport Engineers, «The problems of the track and its maintenance», 1967, No. 491.
- Shahunants G.M, 1972. The influence of the period and the kind of the repair on the manning on current track maintenance which depends on the train traffic volume. The collected scientific articles of Moscow Institute of Transport Engineers, «The problems of the track and its maintenance», Transport, Moscow No. 383, pp. 3-23.
- Shahunants G.M, 1987. The railway track. In: Transport, Moscow.
- «The statute about the performance of the planning-preventive repairing track work on the Ukrainian railways», 2004. Approved by the Ukrzaliznytsia Decree of 10 August 2004, No. 630-II3, Kyiv, p 40.
- Yakovleva T.G, 1999. The railway track. In: Transport, Moscow.