

PAPER • OPEN ACCESS

Energy-efficient excavation of the soil of the lower track structure by bulldozers with a combined knife system

To cite this article: K Hlavatskyi *et al* 2020 *IOP Conf. Ser.: Mater. Sci. Eng.* **985** 012038

View the [article online](#) for updates and enhancements.

Energy-efficient excavation of the soil of the lower track structure by bulldozers with a combined knife system

K Hlavatskyi^{1,2}, S Raksha^{1,3} and Y Gorbenko^{1,4}

¹Dnipro National University of Railway Transport named after Academician V. Lazaryan, Lazaryan St., 2, Dnipro, Ukraine, 49010

²kazimir.glavatskij@gmail.com, ³raksha@ukr.net, ⁴yuriygorbenko1984@gmail.com

Abstract. The motivation of the research and further development of the new type combined knife system on the non-return bulldozer blade and the results of the first series of laboratory studies of the process of the soil digging with the non-return blade of the bulldozer with the first set of its physical models, which indicate the feasibility of continuing research in this direction is given. The proposed combined knife system makes it possible to realize oblique digging of the soil on the non-return blade of the bulldozer and maximally complete its orientation in the prism of the soil before the blade in order to increase the productivity of the bulldozer with non-return blade by decreasing soil losses in the side rollers, decreasing the time of filling and digging the soil by decreasing the coefficient of specific soil resistance to digging. The paper substantiates the technology of more efficient use of bulldozers with non-return blade compared to their traditional counterparts, which is possible due to the use of the new combined knife system, and argues in favor of expanding the technological capabilities of the bulldozer with non-return blade, equipped with the proposed engineering solutions of the new type knife system with different digging angles and spatial inclination of cutting edges.

1. Problem statement

Ground transportation vehicles, to which bulldozers belong, are widely used in the building of earthen structures, in particular, the lower structure of roads and railways. Bulldozers are also widely used in the construction of building sites at the initial and final stages. Therefore, they must be highly efficient and productive when performing technological operations.

Important parameters when evaluating the energy efficiency of a bulldozer are the specific coefficient of soil resistance to digging, which minimization is one of the directions of scientific research during all the time of development and creation of new equipment in our country, as well as the productivity, energy intensity and material intensity of the technological processes performed by it. Taking into account the general tendency of achieving the best performance of bulldozers due to the development of new technical solutions of their working equipment, the main attention is paid to improving the design of the main working body of the bulldozer - the blade and its knife system.

2. Analysis of recent research

The study of bulldozer equipment and its knife systems has been reflected in a number of papers, including classic publications [1, 2, 3], patents [4, 5] and dissertations [6, 7]. However, the study of issues related to changing the profile of the knife system for soil digging intensification is relevant, as it is directly related to improving the productivity of bulldozers, their efficient use and energy saving.



Previously investigated flat and space knife systems based on bulldozer equipment with non-return blade (Figure 1) provide the reduction of specific energy intensity of soil digging due to replacement of blocked digging by semi-free or free one and, for this purpose, have constructive execution of knife systems, combined from separate sections and allow one to divide the straight cutting edge of a traditional flat knife into separate proportional segments and to move them relatively vertically, horizontally and at an angle. At the same time loosening teeth are set on separate plates of the knife system for the intensification of solid soil digging.

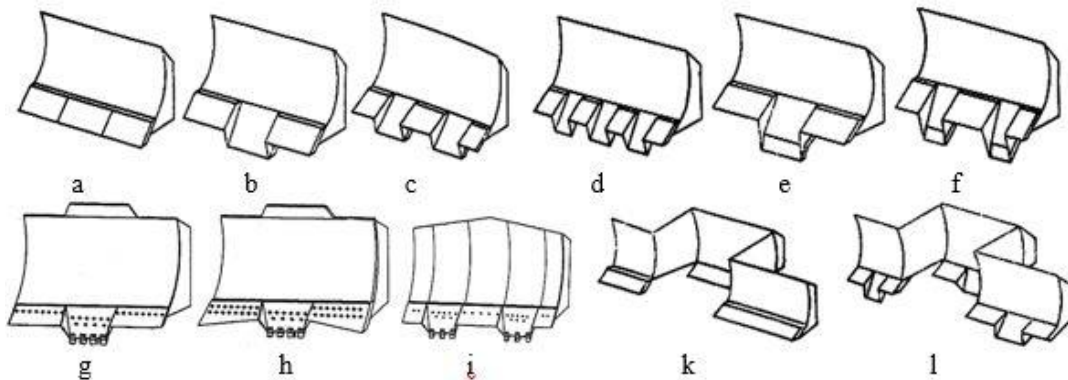

Figure 1. Schemes of known knife systems for the bulldozer blade: a –traditional one with a straight blade; b –with a medium projecting knife; c –with two projecting knives; d –with three projecting knives; e –with a medium knife and a variable cutting angle; f –with two projecting knives and a variable cutting angle; g –with a medium trapezoidal knife; h –with a medium trapezoidal knife and sloping side blades; i –with two medium trapezoidal knives; k – multisection blade; l –multi-section blade with projecting knives.

When the soil digging with a bulldozer with a non-rotary blade and the traditional knife system (Figure 2, a, b), the significant symmetrical loss of cut soil in the side rollers is observed, which reduces the performance of the bulldozer by increasing the path of full prism recruitment and the corresponding increase in cycle time. Symmetrical soil losses can be avoided by using a rotary blade (Figure 2, c) and directing the soil to the desired direction.

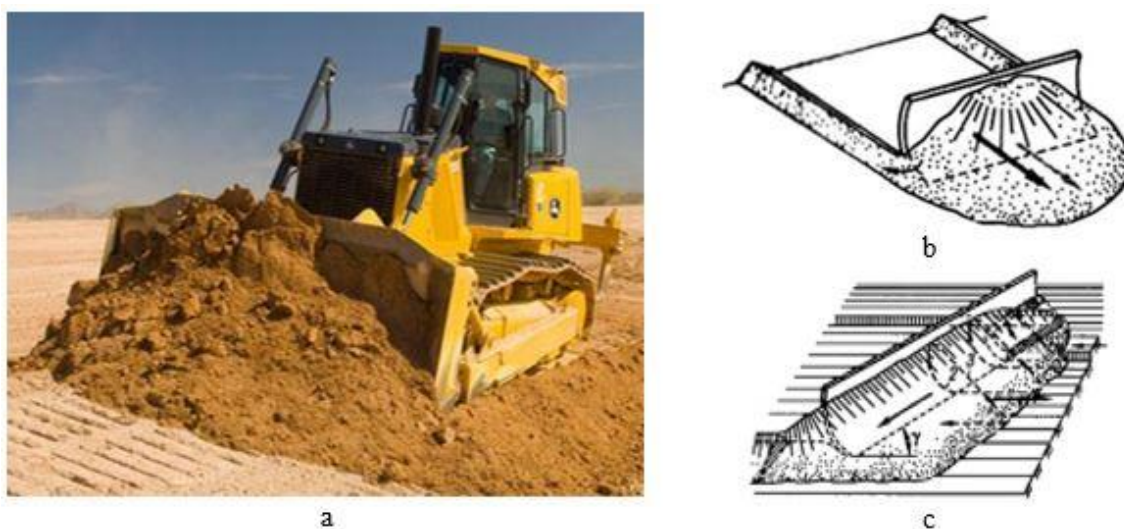

Figure 2. Loss of soil to the sides when digging by a bulldozer: a, b – with a traditional blade; c – with a rotary blade.

To significantly improve productivity, the simultaneous work of bulldozers with non-return blade (Figure 3, a) and with rotary blade (Figure 3, b) should be used, which has significantly lower soil losses in the side rollers, or these losses are absent until the full prism of ground.

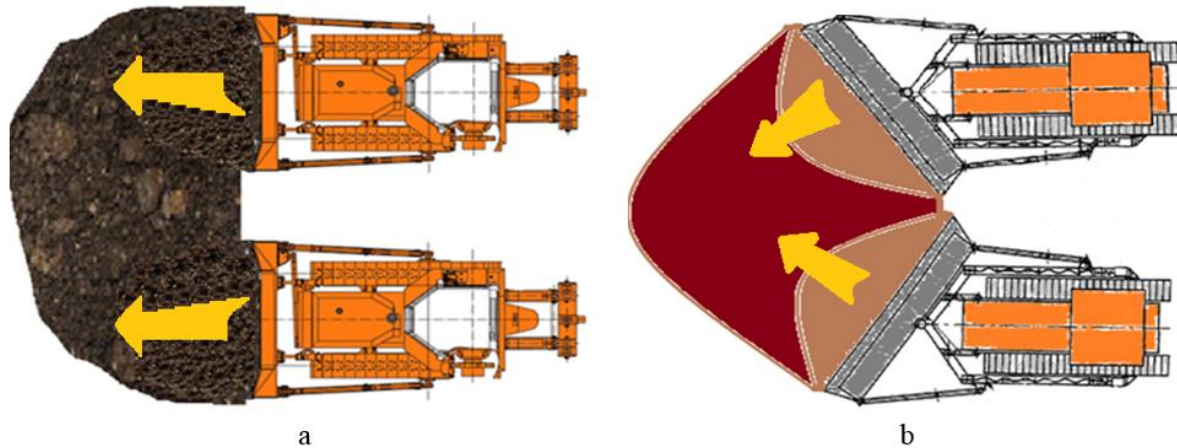

Figure 3. Technology flow charts of the bulldozers simultaneous work: a – with a non-return blade; b – with a rotary blade.

3. The purpose of the work

Is to justify the conditions of energy-efficient soil digging by a non-return blade of the bulldozer with a combined new type knife system, through which it is possible to increase the efficiency and productivity of the bulldozer.

4. Basic material

Achieving this goal is ensured by the installation on the non-return blade of the bulldozer with a combined knife system, which uses exclusively oblique soil digging, creates conditions for directing soil chips separated from the array inside the prism of the soil before the blade, replaces the blocked digging of the soil with a semi-free one [8, 9].

In the combined knife system of the new type, the cutting knives are made of separate plates and are connected in pairs and with blade so that the cutting edges are symmetrical relative to the longitudinal vertical plane of the blade symmetry at a given angle between themselves in the front and vertical projections, and the knife plates are installed at an acute angle to the horizontal in such a way as to ensure exclusively oblique digging of the soil and its orientation in the prism before the blade with minimal losses (Figure 4). When using different number of cutting blades pairs it is possible to get an analogy of technological scheme for bulldozers with rotary blades simultaneous work (Figure 3, b).

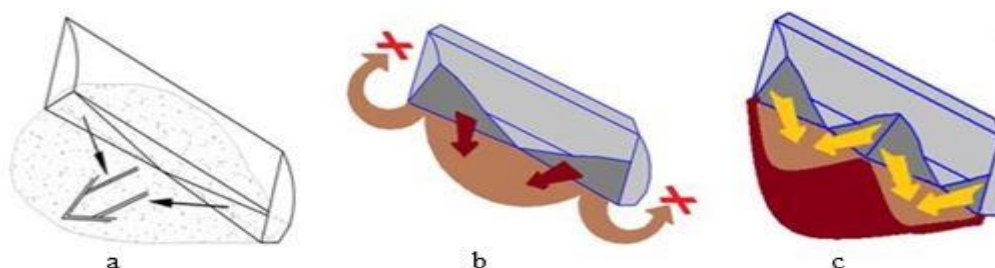

Figure 4. Schematic diagrams of the proposed spatial knife systems: a - with one pair of knives located within the height of the traditional knife system with a continuous straight cutting edge installation; b - with one pair of knives mounted at an angle equal to the angle of the traditional knife system installation; c - with two pairs of knives mounted at an angle, similar to the scheme (b).

A new-type spatial knife system with a non-return blade can solve a number of technological problems which are usual for basic bulldozer analogues (Figure 5), used in the development of the technical solution, namely: to effectively destroy a solid soil similar to a mulch (Figure 5, a) with the tips of knives tilting the blade forward; to carry out exclusively oblique soil digging similar to a bulldozer with a rotary blade (Figure 5, b); to dig the soil more effectively than the traditional non-return bulldozer blade (Figure 5, c).



Figure 5. Similar bulldozers for the development of a new type spatial knife system: a – a snubber; b – with a rotary blade; c – with a non-return blade.

Schematic diagrams of the proposed technical solution of the non-return blade of the bulldozer with the new type combined blade system (Figure 6) can be performed in two main variants: with the placement of the proposed combined blade system within the height of the traditional flat blade system with a straight cutting edge (Figure 6, a) and with its knives installed at an angle equal to the knife installation angle of the traditional knife system. In this case, the combined knife system will extend beyond the height of the traditional knife and will rest not only on the support surface of the traditional knife system, but also on the front blade leaf (Figure 6, b). This approach to the development of a new type combined knife system on a non-return blade is conditioned by the possibility of comparing the efficiency of its technological application with the traditional blade.

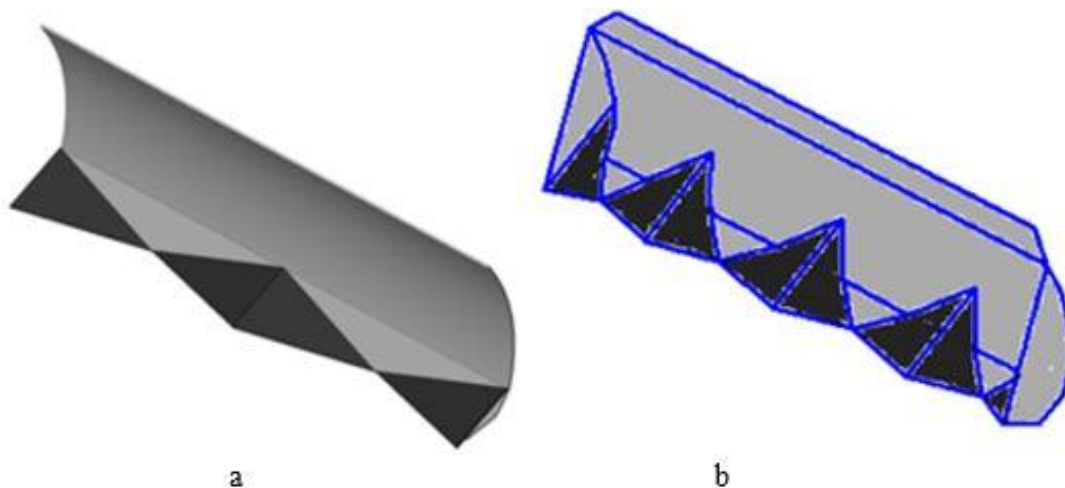

Figure 6. Schematic diagrams of the non-return blade of the bulldozer with the combined knife system: a – located within the height of the traditional knife system; b – with knives at the same cutting angle as for the traditional knife system.

Investigations of technological schemes of work of the non-return blade of a bulldozer with the new type combined knife system involves establishing the efficiency of its work depending on the location of the vertices of the cutting edges of the knives that make up its construction (Figure 7, points 1, 2, 3).

From the experience of similar studies conducting [1] it is obvious that the displacement of points 2 and 3 in height will have an impact on the energy intensity of the digging process.

From the point of view of the proposed knife system technology application, such displacement of points 2 and 3 will lead to two essential types of the soil surface topography: a flat surface (Figure 8, a) and a ridge surface (Figure 8, b).

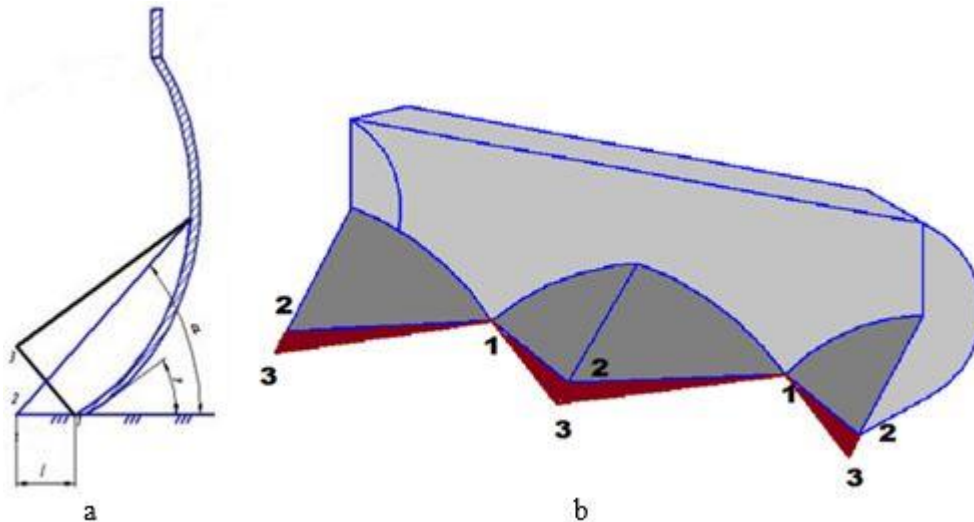

Figure 7. Scheme of mutual arrangement of vertices of cutting edges of the combined knife system:
a – a side view; b – an axonometry.

In this case, the flat surface can be formed by the proposed knife system when placing points 1 and 2 in one horizontal plane, and the comb surface when displacing points 2 above or below point 1.

The first series of scientific researches performed on physical models (Figure 9) proves their effectiveness in comparison with the traditional non-return blade as a whole [10].

To compare the results of theoretical and experimental studies of the new type combined knife system on the non-return blade of the bulldozer from the correctness point of view, the non-return blade of the bulldozer with the most common traditional knife system, which performance indicators are well known and undeniable, was adopted.

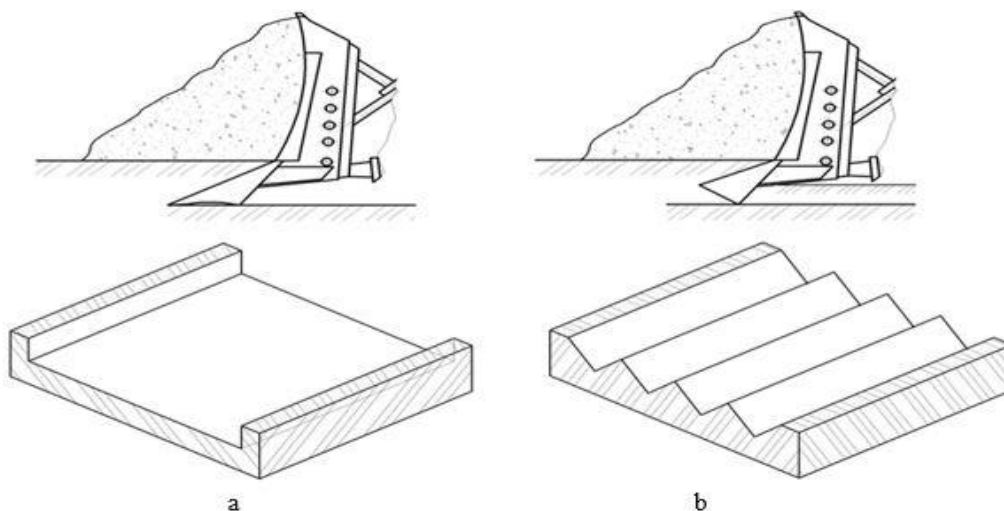

Figure 8. Schemes of soil digging and types of a soil surface relief: a - flat at the placement of knives edges points 1-2-3 in one plane; b - crest at vertical displacement of points 2 (3) relative to point 1.

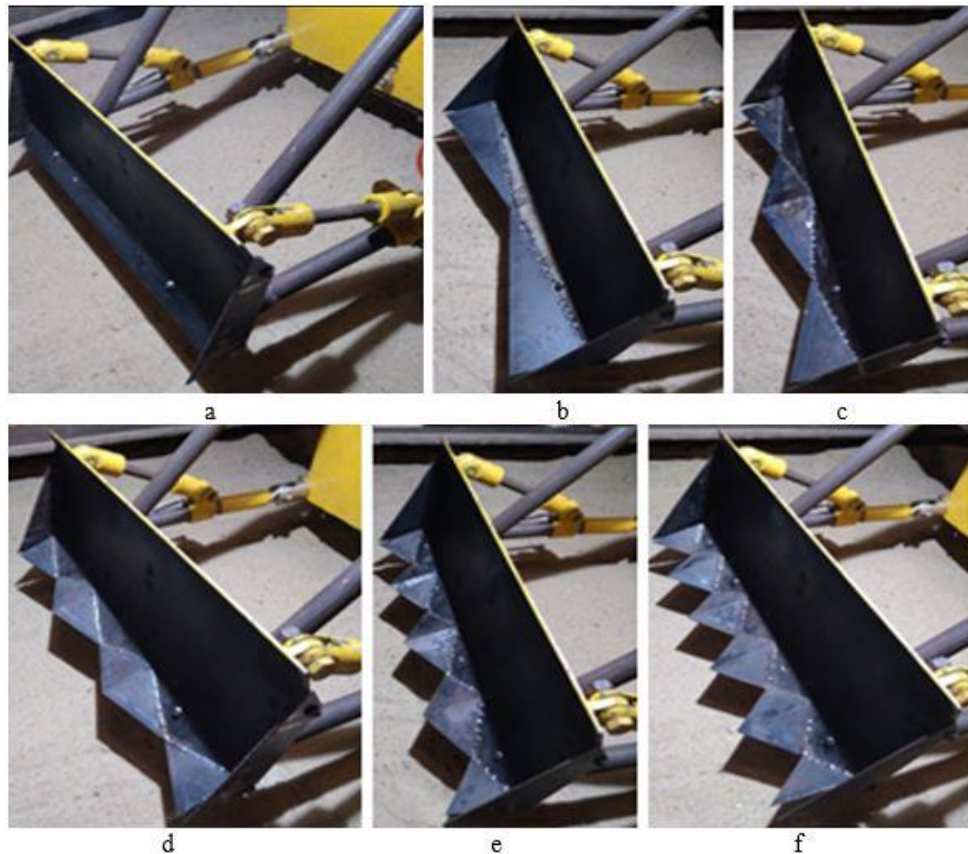

Figure 9. Physical models of traditional and combined knife system on a non-return blade: a – a bulldozer blade with a traditional knife system; b, c, d, e, f - with a combined knife systems with one, two, three, four and five pairs of knives.

5. Conclusions

The investigated physical model of a non-return blade of a bulldozer with the combined knife system has significant advantages over the non-return blade of a bulldozer with the traditional knife system in all basic experimental parameters, namely: the average productivity has increased by 5%, the average digging power has decreased by 30%, the average specific energy consumption decreased by 41% and the average specific drag coefficient has decreased by 40% [10].

The highest percentage of the indicated coefficients positive change corresponds to the physical model of the non-return blade of the bulldozer with the combined knife system with the longitudinal displacement of the knives edges up to 50 mm and one pair of knives.

The smallest percentage of positive change of the specified parameters corresponds to the physical model of the non-return blade of the bulldozer with the combined knife system with the 55 mm longitudinal displacement of the blades edges and two pairs of knives, and in this case the average digging force of the physical model of the non-return blade system is 3.4% higher than for the corresponding bulldozer blade with the traditional knife system, and productivity is 35% down for the bulldozer with the traditional blade system.

An alternative to the physical models of a bulldozer with a non-return blade and a combined knife system in the second place is a model with a 50 mm longitudinal offset of knife edges and 5 knife pairs, in the third place a 50 mm long knife edge offset and 4 pairs of knives and in the fourth place is a model with a longitudinal offset of the knives edges equal to 50 mm and the number of knives pairs equal to 3 [10].

In [10] research on the methods of combined knife systems has been carried out to determine their rational parameters.

It should be noted that the increase in the prism of soil drag before the blade is also due to the installation of side scroll blades of the enlarged size.

The overall reduction of the specific energy consumption of the soil excavation process is also due to the replacement of the blocked soil excavation by a semi-free one.

In further research, the authors intend to compare the results of their research with the latest scientific advances in knife systems on a non-return blade, in particular with a flat knife system with a protruding middle knife, a flat knife system with protruding knives and a side plate, as well as with trapezoid protruding knives and side plates. Such a comparison will allow us to draw conclusions about the relative energy efficiency and other major technological indicators that affect the performance of the bulldozer and establish the area of its rational use.

From the point of view of ensuring the manufacturability and application of the proposed technical solution of the combined knife system, its implementation on the in-situ machine is provided in the form of separate modules, which in the first stage of implementation in production and operation will not violate the integrity of the basic design of the blade, and in the future, in the case of demand for this knife system, it is planned to develop a new design of the blade in order to change only the part of the knife system.

In further studies of the combined blade system on the non-return blade, on the basis of the obtained research results, it is planned to construct regression models to determine the ranges of rational and optimal parameters of the soil digging process with the non-return blade of the bulldozer with the combined knife system, as well as to compare the results of theoretical and experimental research.

References

- [1] Khmara L, Kravets S, Nichke L, Nazarov V, Sabluk M and Nikitin V 2010 The soil-moving machine *Tutorial* (Kharkov Ukraine:Kharkiv National Automobile & Highway University) p 557
- [2] Khmara L, Kravets S, Skoblyuk M, Nikitin V, Derevyanchuk M and Suponev V 2014 Soil-moving machine *Tutorial* (Kharkov Ukraine:Kharkiv National Automobile & Highway University) p 548
- [3] Blokhin S and Malich N 2006 The main parameters of technological machines *Tutorialmachines for work with soil* (Kyiv, Ukraine: publishing house Vyshcha Shkola) p 497
- [4] Khmara L, Talalay V and Sokolov I 2006 Bulldozer blade with rotary knife system: *Patent № 112205* (Dnipro Ukraine:Dnipro Academy of Building and Architecture)
- [5] Khmara L, Talalay V and Sokolov I 2006 Bulldozer blade *Patent № 116566* (Dnipro Ukraine:Dnipro Academy of Building and Architecture)
- [6] Korotkikh V 1995 Research and development of bulldozer with protruding knives and side gussets *Author's abstract dissertation Candidate of Technical science* (Dnipro Ukraine: Dnipro Academy of Building and Architecture) p 21
- [7] Talalay V 2008 Intensification of soil development by bulldozer blade improvement of the parameters of the knife system *Dissertation Candidate of Technical science* (Dnipro Ukraine: Dnipro Academy of Building and Architecture) p 186
- [8] Bohomaz V, Hlavatskyi K, Dorohokuplya M, Krasnoshchok S, Proskurnya V and Sereda O 2016 Bulldozer blade with combined knife system *Patent № 112205* (Dnipro Ukraine: Dnipro National University of Railway Transport named after Academician V. Lazaryan)
- [9] Glavatskyi K, GorbenkoY and Anofriyev P 2019 Investigation of the process of digging the soil with a bulldozer non-return blade with a bulk knife system *Bulletinof DNUZT* (Dnipro Ukraine:Dnipro National University of Railway Transport named after Academician V. Lazaryan) **79** p 230
- [10] Raksha S, Glavatskyi K and GorbenkoY 2020 Investigation of the process of digging the soil by a physical model of bulldozer equipped with a non-rotating blade with a variable combined three-dimensional knife system *Bulletin of Kharkiv National Automobile & Highway University* (Kharkiv, Ukraine: Kharkiv National Automobile & Highway University) **88** 2 pp 86–92